

## Valves



## Gas interception valves

RSO/T & RW (E1451 rev. 05 - 27/07/2017)

## GENERAL WARNINGS:



■ All installation, maintenance, ignition and setting must be performed by qualified staff, respecting the norms present at the time and place of the installation.

■ To avoid damage to people and things, it is essential to observe all the points indicated in this handbook. The reported indications do not exonerate the Client/User from observing general or specific laws concerning accidents and environmental safeguarding.

■ The operator must wear proper DPI clothing (shoes, helmets...) and respect the general safety, prevention and precaution norms.

■ To avoid the risks of burns or high voltage electrocution, the operator must avoid all contact with the burner and its control devices during the ignition phase and while it is running at high temperatures.

■ All ordinary and extraordinary maintenance must be performed when the system is stopped.

■ To assure correct and safe use of the combustion plant, it is of extreme importance that the contents of this document be brought to the attention of and be meticulously observed by all personnel in charge of controlling and working the devices.

■ The functioning of a combustion plant can be dangerous and cause injuries to persons or damage to equipment. Every burner must be provided with certified combustion safety and supervision devices.

■ The burner must be installed correctly to prevent any type of accidental/undesired heat transmission from the flame to the operator or the equipment.

■ The performances indicated in this technical document regarding the range of products are a result of experimental tests carried out at ESA-PYRONICS. The tests have been performed using ignition systems, flame detectors and supervisors developed by ESA-PYRONICS. The respect of the above mentioned functioning conditions cannot be guaranteed if equipment, which is not present in the ESA-PYRONICS catalogue, is used.

## DISPOSAL:



To dispose of the product, abide by the local legislations regarding it.

## GENERAL NOTES:



■ In accordance to the internal policy of constant quality improvement, ESA-PYRONICS reserves the right to modify the technical characteristics of the present document at any time and without warning.

■ It is possible to download technical sheets which have been updated to the latest revision from the **www.esa-pyronics.com** website.

■ The products manufactured by ESA-PYRONICS have been created in conformity to the **UNI EN 746-2:2010** Norms: Equipment for industrial thermal process - Part 2: Safety requirements for combustion and the movement and treatment of combustible elements. This norm is in harmony with the Machine Directive **2006/42/CE**. It is certified that the products in question respect all the requirements prescribed by the above mentioned Norms and Directives.

■ Certified in conformity with the **UNI EN ISO 9001** Norm by DNV GL.

## CERTIFICATIONS:



### EN331

Ball and male cone shaped valves with bottom end closed for gas systems in buildings.



Butterfly valve "LUG" type - DVGW NG-4313BU0007 conform to Directive 97/23EC "PED" and 94/9/CE "ATEX".



The products conform to the requests for the Euroasia market (Russia, Belarus and Kazakhstan).

## CONTACTS / ASSISTANCE:



### Headquarters:

Esa S.p.A.  
Via Enrico Fermi 40  
24035 Curno (BG) - Italy  
Tel +39.035.6227411  
Fax +39.035.6227499  
[esa@esacombustion.it](mailto:esa@esacombustion.it)

### International Sales:

Pyronics International s.a.  
Zoning Industriel, 4ème rue  
B-6040 Jumet - Belgium  
Tel +32.71.256970  
Fax +32.71.256979  
[marketing@pyronics.be](mailto:marketing@pyronics.be)

[www.esapyronics.com](http://www.esapyronics.com)

The RSO/T & RW are respectively gas shut-off ball (RSO/T series) and butterfly (RW series) valves. They are available with threaded or flanged connections according to size and model.

### APPLICATIONS

- Fuel gas interception.
- Fuel gas manual partializing and regulation

### CHARACTERISTICS

#### RSO/T & RSO/T-Y SERIES BALL VALVES:

- Available sizes RSO/T series : from Ø 1/4" to Ø 2"
- Available sizes RSO/T-Y series: from Ø 1/4" to Ø 1"
- Maximum working pressure: 5 bar
- Maximum fluid temperature: -20°C +60°C
- Flow direction and mounting position: any
- Reference Norm: EN331

#### MATERIAL COMPOSITION:

- Valve body: brass
- Ball: brass
- Tightness: P.T.F.E.
- External "O" ring seal : NBR

#### RSO/T-F SERIES BALL VALVES:

- Available sizes: from DN50 PN16 to DN125 PN16
- Maximum working pressure: 5 bar
- Maximum fluid temperature: -20°C +120°C
- Flow direction and mounting position: any
- Gas approval: DVGW Reg. N.93.01 e 941
- Conformity: PED EN10204-3.1

#### MATERIAL COMPOSITION:

- Valve body: Cast iron G40
- Ball: ottone
- Tightness: P.T.F.E.
- External "O" ring seal: NBR

#### RW SERIES "LUG" TYPE BUTTERFLY VALVES:

- Available sizes: from DN40 PN16 to DN300 PN16
- Lever adjustment positions: 10
- Maximum working pressure: 16 bar
- Maximum fluid temperature: -23°C +82°C
- Flow direction and mounting position: any
- Gas approval: DVGW NG-4313BU0007
- Conformity: 97/23/EC "PED" & 94/9/CE "ATEX"

#### MATERIAL COMPOSITIONS:

- Valve body: cast iron G40
- Disc: AISI316
- Tightness: NBR
- Lever: aluminium

#### RSO/T & RSO/T-Y



F1451103

#### RSO/T-F



F1451104

#### RW



F1451105

## DESCRIPTION

The gas interception valves are divided into two categories: ball valves, identified by the RSO/T, RSO/T-Y, RSO/T-F series and RW LUG type butterfly valve series. The valves have a body with ball or throttle closing as well as a manual lever placed at the valve end; the RW series butterfly valves are provided with 10 notches for the posi-

tioning of the closing lever. The connections can be threaded or flanged, according to the models. The RW series butterfly valves have "LUG" type connections that allow the valve to block at the flanges, due to the fact the the fastening holes are threaded.

## CAPACITY TABLE

### RSO/T & RSO/T-Y

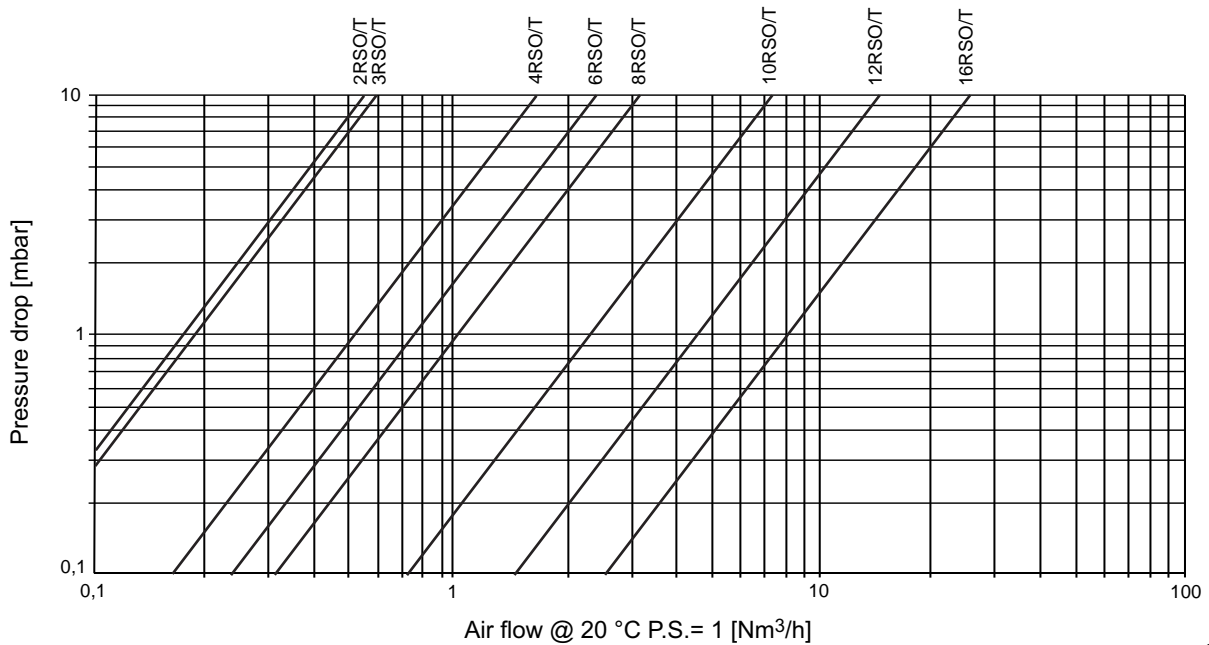

G1451101

### RSO/T-F

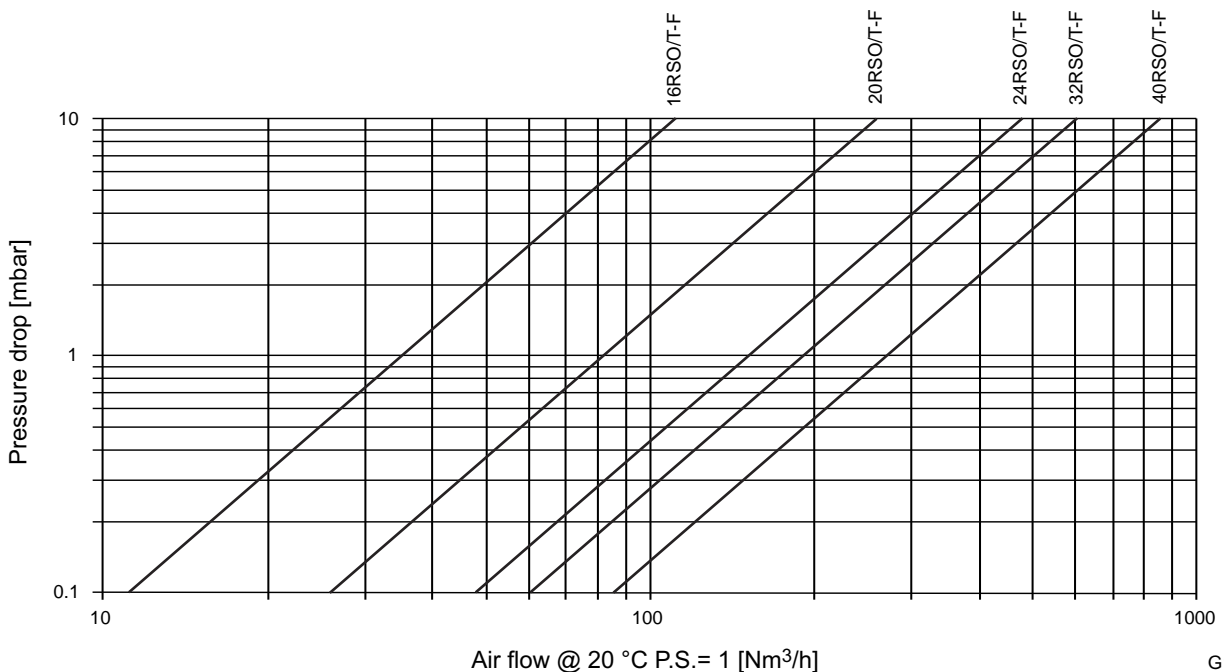

G1451102

**RW**

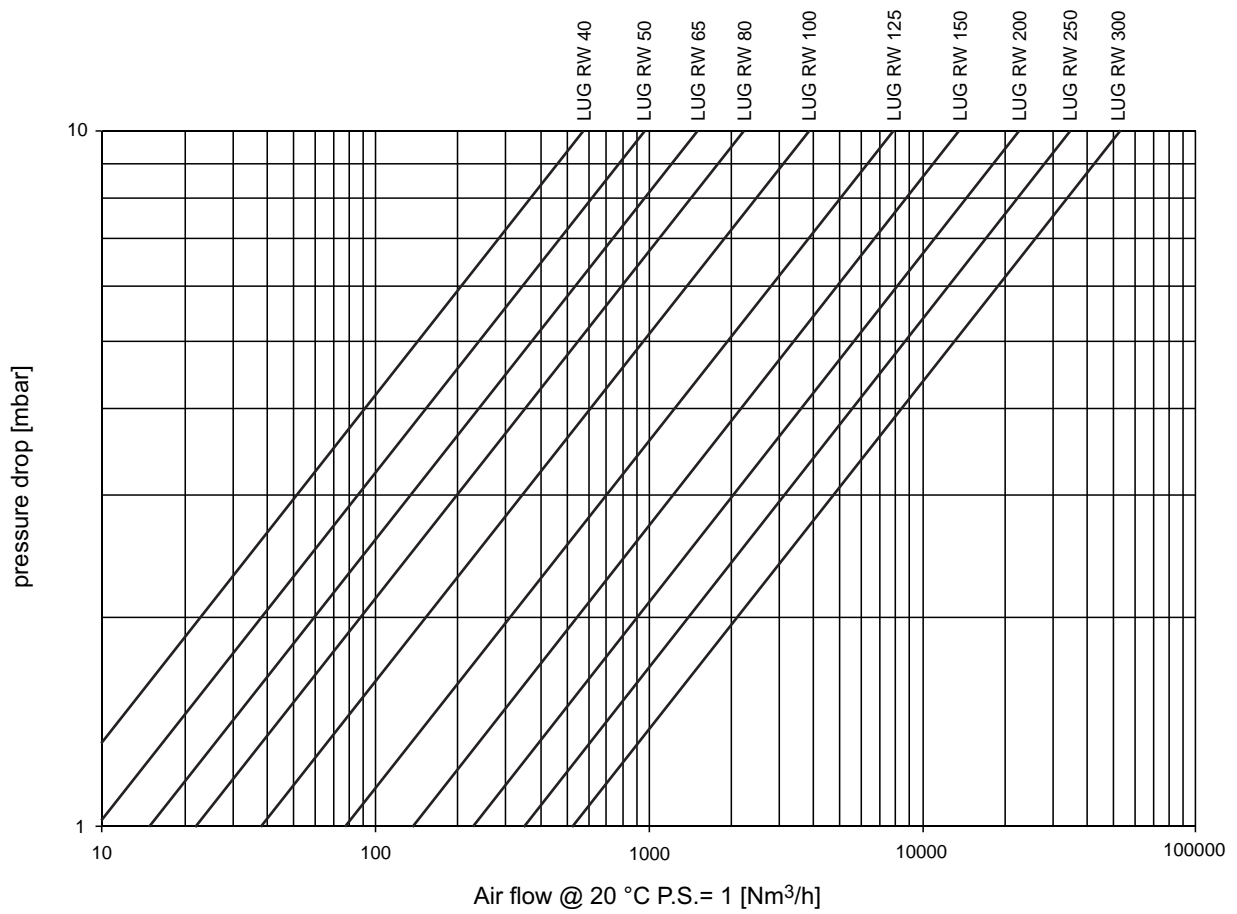

G1451103

## WARNINGS

- Make sure that the working pressure and the fluid temperature are lower than the maximum allowed values.
- The RSO/T & RW valve series are supplied without coupling flanges or gaskets. The flanges and gaskets to be applied must be suited to the valve type and its application.
- Check that valve installation is carried out correctly before starting the fluid flow through the pipeline.

- In case of valve malfunctioning, follow the indications on the "MAINTENANCE" chapter of this manual or contact the ESA-PYRIONICS service center.
- Any modification or repair done by third parties could compromise the application safety and automatically cause the general guarantee conditions to expire.

## INSTALLATION

Place the valve in conditions so as not to be exposed to direct radiation or heat sources, or in contact with combustion products, liquids, solvents or corrosive gases.

- Check that the line pressure is lower than the maximum working pressure allowed.
- The valve can be installed in any position.
- Make sure that no foreign body has entered the valve before assembling it. If necessary, blow with compressed air.
- Check the correct alignment of the connecting pipes. Keep a certain distance from the walls allowing air to circulate freely and allowing the lever to work correctly.

### THREADED MODELS:

- 1 - Make sure that the threads conform to those of the valve that is to be installed (**pos. 1**) according to the UNI ISO 7/1 norm.
- 2 - Do not use the lever to fasten the valve (**pos. 1**), but use an appropriate wrench (serie RSO/T RSO/T-Y).
- 3 - Use thread seal paste or a similar product on the male threads of the pipes (**pos. 2**).

### FLANGED MODELS:

- 1 - Weld the flanges (**pos. 1**) on the ends of the pipes, eliminating any welding burrs.
- 2 - Place the gaskets (**pos. 2**) between the flanges (**pos. 01**) and the valve (**pos. 4**) and insert the bolts (**pos. 3**).
- 3 - Using appropriate tools, progressively cross fasten the bolts (**pos. 3**).
- 4 - Avoid overtightening and mount without tension.

The RW series butterfly valves have "LUG" type connections that allow the valve to block at the connecting flanges due to the fact that the fastening holes are threaded.

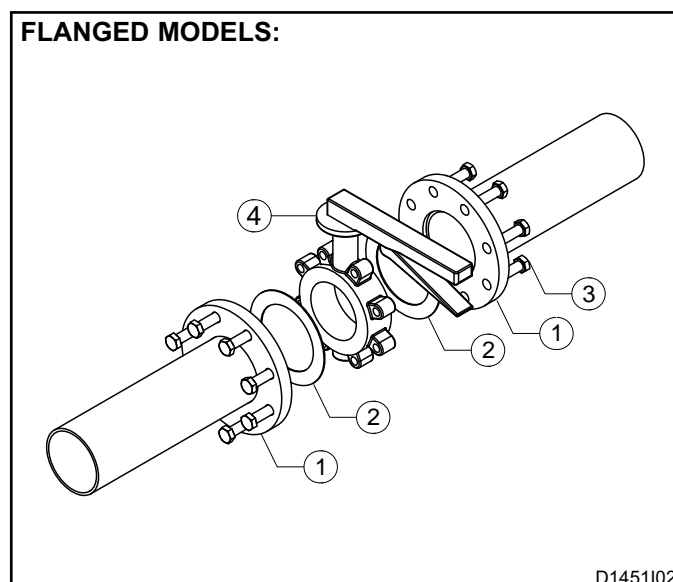
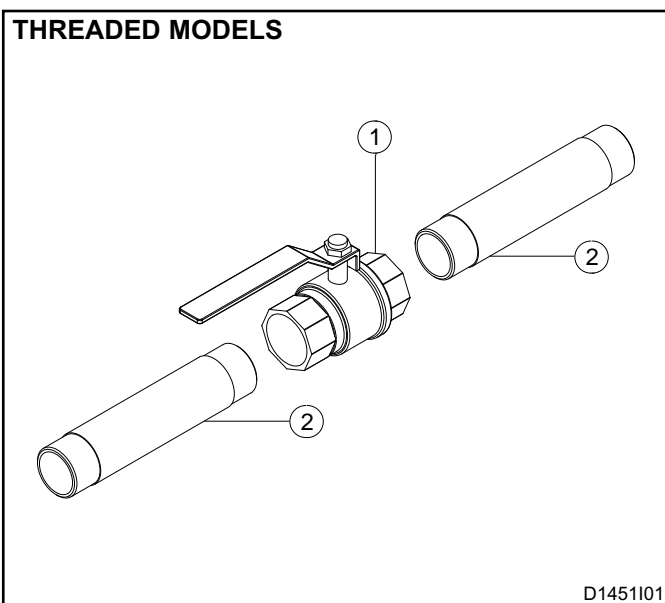

## REGULATION

The RSO/T, RSO/T-Y e RSO/T-F series ball valves do not allow flow regulation or at least they are not predisposed for this. The RW "LUG" type series butterfly valves have

10 notches for the positioning of the closing lever, and therefore can allow flow regulation or partializing.



## GENERAL MAINTENANCE PLAN

Maintenance and installation must be carried out by qualified personnel, respecting the norms in force, once installation has been done it is always appropriate to per-

form a tightness test on the threads or flanged connections.

Operation	Type (*)	Advised Time	Notes
<b>Gasket integrity</b>	O	annual	Check that there are no external leaks
<b>Thread integrity</b>	O	annual	Check that there are no external leaks
<b>Lever movement</b>	O/E	twice a year	Check the integrity of the lever and check that there is nothing impeding the movement of the valve
<b>Butterfly valve maintenance</b>	E	annual	Check the valve conditions

### NOTES:

Key: O = ordinary / E = extraordinary

(\*) we advise you to replace the gaskets every time the valve is disassembled.

## ORDINARY MAINTENANCE

For correct maintenance of the RSO/t & RW valves, carefully follow the instructions below. Before doing anything with the plant on, make sure that the process safety and the operator's safety is not compromised, if necessary perform inspection with plant off.

### INTEGRITY CHECK

■ The integrity of the gaskets and the threads can be checked visually. If necessary, use leak detector liquid.

### VALVE/LEVER MOVEMENT

■ The inspection that there is nothing hindering the valve movement takes place by performing a complete visual check that there is no friction or anything else limiting the course of the valve.

## EXTRAORDINARY MAINTENANCE

For correct maintenance of the RSO/T & RW valve, carefully follow the instructions below that must be carried out with the plant off.

### BOLT FASTENING

■ The bolt fastening check must be done with the plant off.

### MAINTENANCE OF THE BUTTERFLY VALVE - GASKET REPLACEMENT

**1** - Place the valve in the completely closed position, otherwise it will not be possible to extract it from the pipeline (serie RW).

**2** - Progressively unscrew the screws that cross fasten the valve. Extract the valve and check the conditions of the internal components.

**3** - Clean the inside of the valve body with a clean cloth and compressed air. Do not use tools that could damage the internal parts.

**4** - Check that the valve moves without friction.

**5** - Replace the gaskets and reassemble the valve in its seat, according to the steps indicated in the "INSTALLATION" section.

**6** - Finally check that the valve moves freely without impediments.

**OVERALL DIMENSIONS - RSO/T**

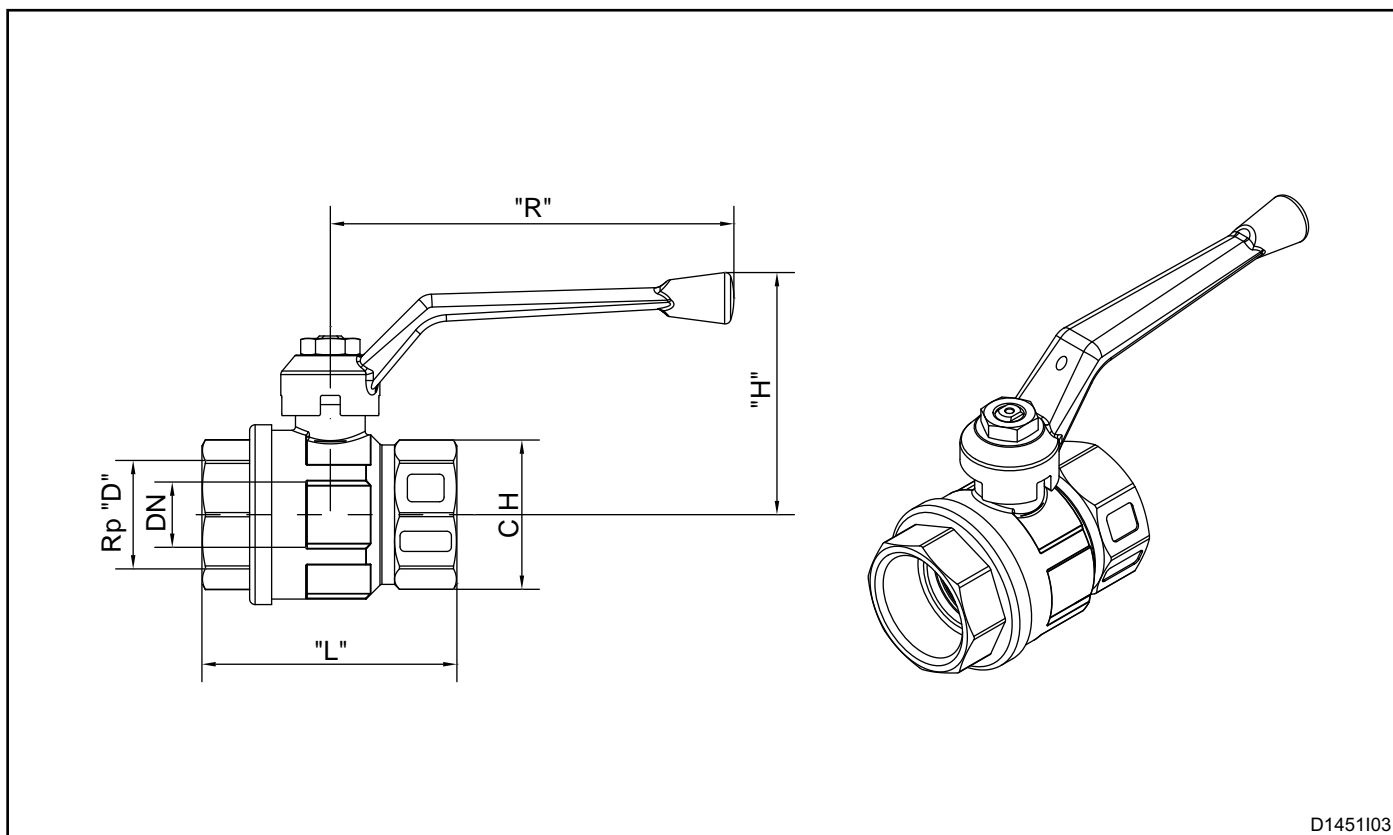

D1451103

Model	Rp "D"	DN	"L" [mm]	"CH" Key	"R" [mm]	"H" [mm]	Kv (*)	MOP	Weight [Kg]
2 RSO/T	1/4"	8	51.5	20	96	42	5.4	5 bar	0.15
3 RSO/T	3/8"	10	51.5	20	96	42	6	5 bar	0.14
4 RSO/T	1/2"	15	62	25	96	46	16.3	5 bar	0.22
6 RSO/T	3/4"	20	69	31	121	58	29.5	5 bar	0.36
8 RSO/T	1"	25	83	38	121	62	43	5 bar	0.55
10 RSO/T	1.1/4"	32	96	48	151	76	89	5 bar	0.99
12 RSO/T	1.1/2"	40	108	54	151	82	230	5 bar	1.49
16 RSO/T	2"	50	126	67	160	95	265	5 bar	1.97

(\*) The discharge coefficient Kv is the flow value expressed in m<sup>3</sup>/h to the differential pressure of 1 bar.



**OVERALL DIMENSIONS - RSO/T-Y FF**

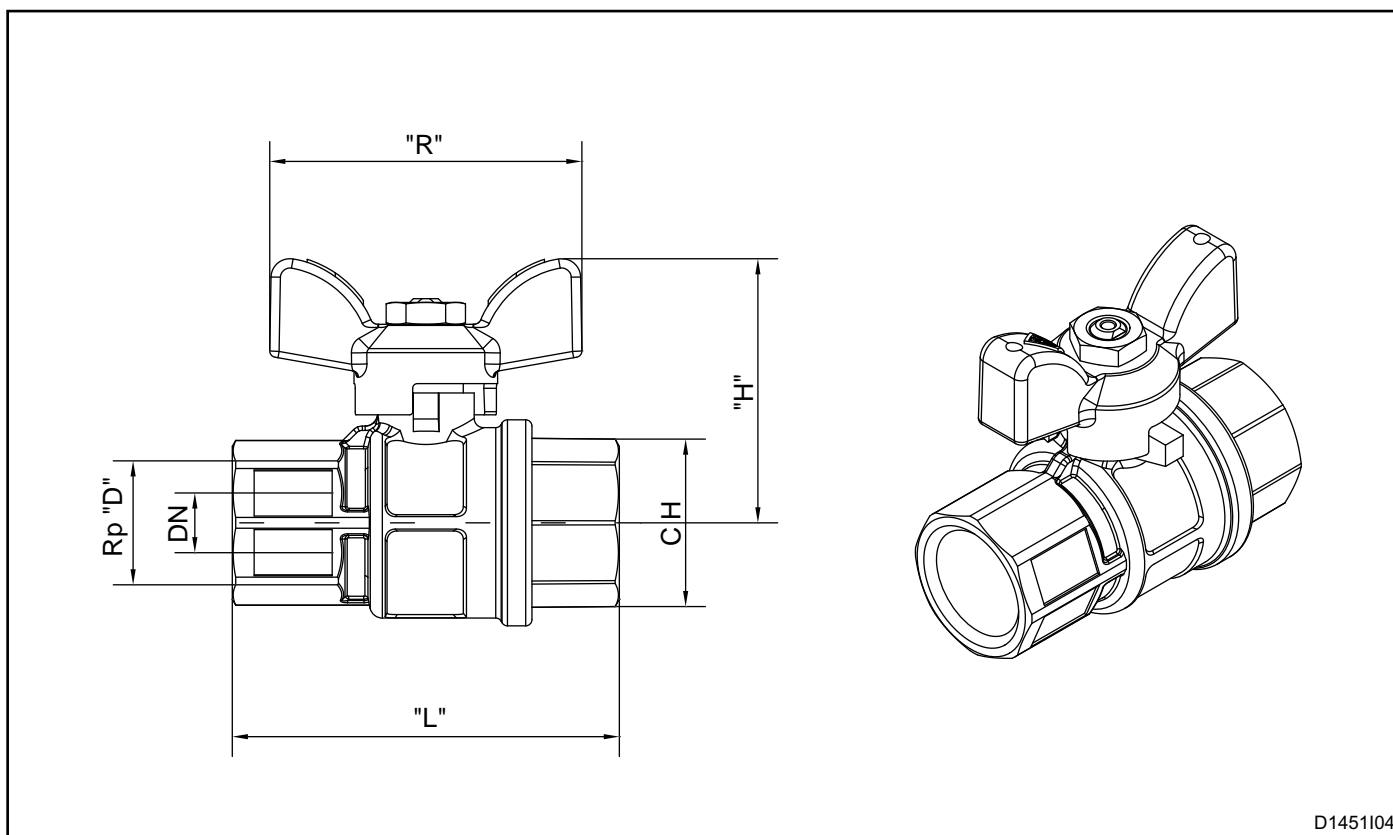

Model	Rp "D"	DN	"L" [mm]	"CH" Key	"R" [mm]	"H" [mm]	Kv (*)	MOP	Weight [Kg]
2 RSO/T-Y FF	1/4"	8	51.5	20	50	42	5.4	5 bar	0.14
3 RSO/T-Y FF	3/8"	10	51.5	20	50	42	6	5 bar	0.12
4 RSO/T-Y FF	1/2"	15	62	25	50	45.5	16.3	5 bar	0.20
6 RSO/T-Y FF	3/4"	20	69	31	64	54.5	29.5	5 bar	0.32
8 RSO/T-Y FF	1"	25	83	38	64	58.5	43	5 bar	0.52

(\*) The discharge coefficient Kv is the flow value expressed in m<sup>3</sup>/h to the differential pressure of 1 bar.

**OVERALL DIMENSIONS - RSO/T-Y MF**

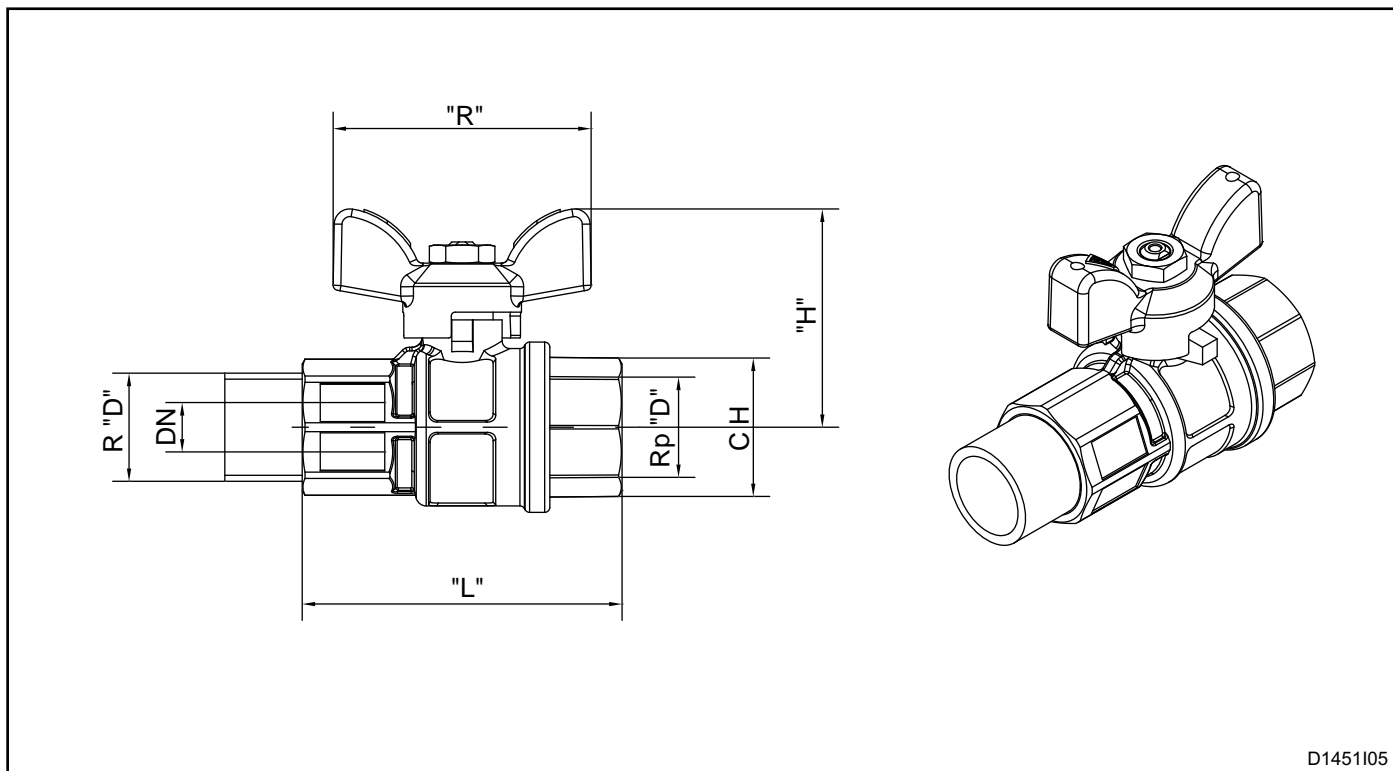

D1451I05

Model	Rp "D"	DN	"I" [mm]	"L" [mm]	"H" [mm]	CH Key	"R" [mm]	"H" [mm]	Kv (*)	MOP	Weight [Kg]
<b>2 RSO/T-Y MF</b>	1/4"	8	12.5	58.5	23	20	50	42	5.4	5 bar	0.16
<b>3 RSO/T-Y MF</b>	3/8"	10	13	59.5	23	20	50	42	6	5 bar	0.13
<b>4 RSO/T-Y MF</b>	1/2"	15	17	72.5	32	25	50	45.5	16.3	5 bar	0.22
<b>6 RSO/T-Y MF</b>	3/4"	20	18.5	81.5	39	31	64	54.5	29.5	5 bar	0.35
<b>8 RSO/T-Y MF</b>	1"	25	21.5	94.5	49	38	64	58.5	43	5 bar	0.55

(\*) The discharge coefficient Kv is the flow value expressed in m<sup>3</sup>/h to the differential pressure of 1 bar.

**OVERALL DIMENSIONS - RSO/T-F**

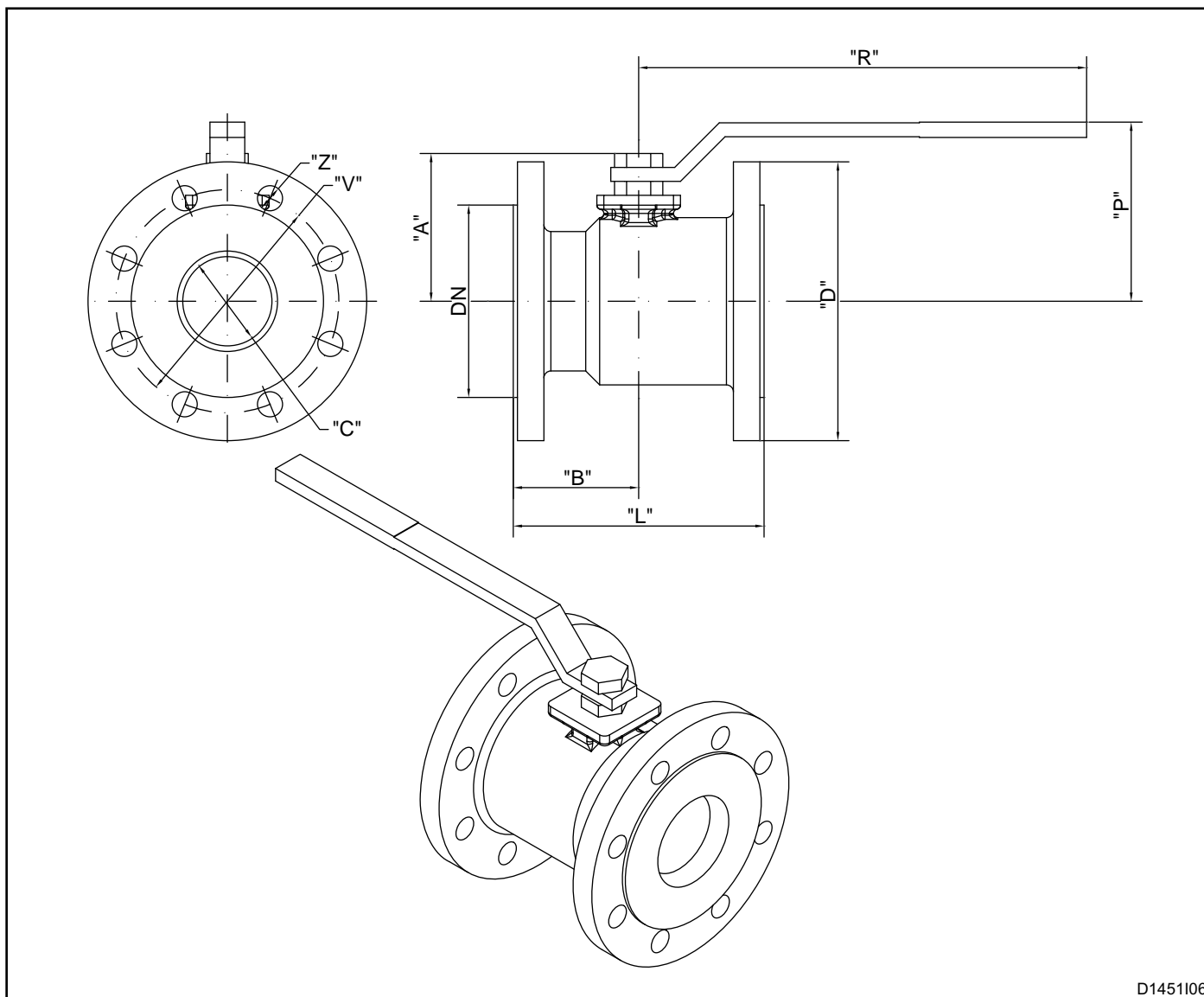

D1451106

Model	DN	A [mm]	D [mm]	B [mm]	L [mm]	C [mm]	P [mm]	R [mm]	V [mm]	Z [mm]	Kv (*)	PN	MOP	Weight [Kg]
16 RSO/T-F	50	78.5	165	75	150	38	103.5	250.5	125	4 x ø 18	180	16	5 bar	7.9
20 RSO/T-F	65	86.5	185	85	170	50.2	112.5	250.5	145	4 x ø 18	390	16	5 bar	10.2
24 RSO/T-F	80	105	200	90	180	64	128.5	321.5	160	8 x ø 18	600	16	5 bar	12.9
32 RSO/T-F	100	114.5	220	95	190	76	138	321.5	180	8 x ø 18	750	16	5 bar	17
40 RSO/T-F	125	137.5	250	100	200	95	157.5	381.5	210	8 x ø 18	1060	16	5 bar	24.8

(\*) The discharge coefficient Kv is the flow value expressed in m<sup>3</sup>/h to the differential pressure of 1 bar

**OVERALL DIMENSIONS - RW**

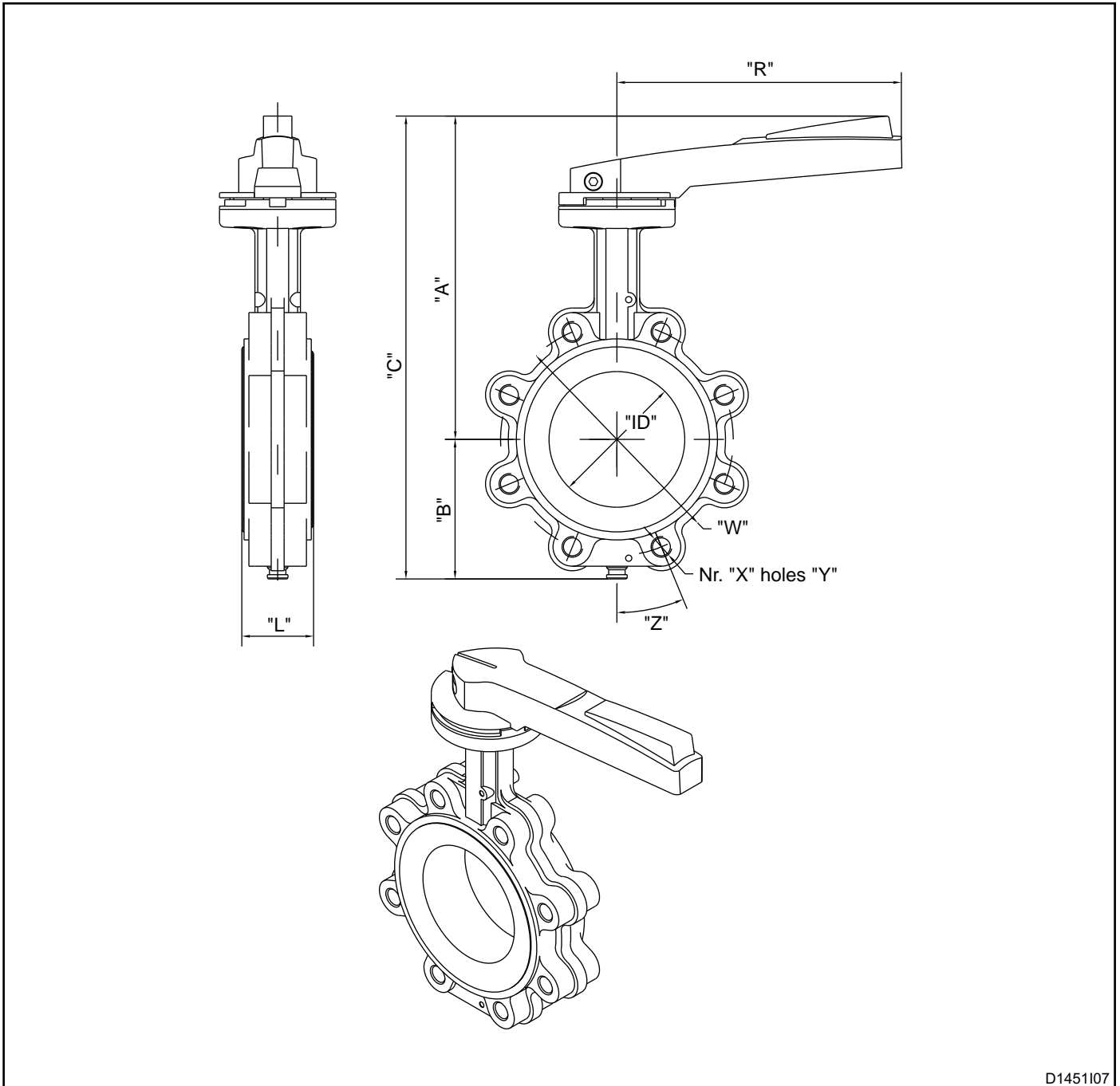

D1451107

Model	DN / ID	"A" [mm]	"B" [mm]	"C" [mm]	"L" [mm]	"R" [mm]	"W" [mm]	"X" [mm]	"Y" [mm]	"Z" [mm]	MOP	Mass [Kg]
12 RW	40	188	70	258	36	160	110	4	M16	45	16 bar	2.5
16 RW	50	203	80	283	46	160	125	4	M16	45	16 bar	3.4
20 RW	65	225	86	311	49	220	145	4	M16	45	16 bar	4.3
24 RW	80	230	96	326	49	220	160	8	M16	22.5	16 bar	5.5
32 RW	100	250	108	358	56	220	180	8	M16	22.5	16 bar	6.6
40 RW	125	277	125	402	59	350	210	8	M16	22.5	16 bar	9.0
48 RW	150	290	137	427	59	350	240	8	M20	22.5	16 bar	11.4
64 RW	200	325	166	491	64	350	295	12	M20	15	16 bar	17.5
80 RW	250	395	199	594	72	500	355	12	M24	15	16 bar	26.8
96 RW	300	432	234	666	81	500	410	12	M24	15	16 bar	41.8

**ORDERING CODE - BALL VALVES**

-   
**01**      **02**

Model		01
1/4" Rp. (DN8)		2
3/8" Rp. (DN10)		3
1/2" Rp. (DN15)		4
3/4" Rp. (DN20)		6
1" Rp. (DN25)		8
1.1/4" Rp. (DN32)		10
1.1/2" Rp. (DN40)		12
2" Rp. (DN50)		16
DN65		20
DN80		24
DN100		32
DN125		40
DN150		48
DN200		64
DN250		80
DN300		96

02		Type
Ball valve (2-16)		RSO/T
Ball valve (2-8)		RSO/T-Y FF
Ball valve (2-8)		RSO/T-Y MF
Ball valve (16-40)		RSO/T-F

**ORDERING CODE - BUTTERFLY VALVES**

RW  
**01**

Model		01
DN40		12
DN50		16
DN65		20
DN80		24
DN100		32
DN125		40
DN150		48
DN200		64
DN250		80
DN300		96