

Accessories



Pressure regulators

Zero Governors (EN88-1)

BZR-REG-II (E5102 rev. 02 - 02/11/2017)

GENERAL WARNINGS:



■ All installation, maintenance, ignition and setting must be performed by qualified staff. Read the instructions before use. This control shall be installed in accordance with the rules in force.

■ To avoid damage to people and things, it is essential to observe all the points indicated in this handbook. The reported indications do not exonerate the Client/User from observing general or specific laws concerning accidents and environmental safeguarding.

■ The operator must wear proper DPI clothing (shoes, helmets...) and respect the general safety, prevention and precaution norms.

■ To avoid the risks of burns or high voltage electrocution, the operator must avoid all contact with the burner and its control devices during the ignition phase and while it is running at high temperatures.

■ All ordinary and extraordinary maintenance must be performed when the system is stopped.

■ To assure correct and safe use of the combustion plant, it is of extreme importance that the contents of this document be brought to the attention of and be meticulously observed by all personnel in charge of controlling and working the devices.

■ The functioning of a combustion plant can be dangerous and cause injuries to persons or damage to equipment. Every burner must be provided with certified combustion safety and supervision devices.

■ The burner must be installed correctly to prevent any type of accidental/undesired heat transmission from the flame to the operator or the equipment.

■ The performances indicated in this technical document regarding the range of products are a result of experimental tests carried out at ESA-PYRONICS. The tests have been performed using ignition systems, flame detectors and supervisors developed by ESA-PYRONICS. The respect of the above mentioned functioning conditions cannot be guaranteed if equipment, which is not present in the ESA-PYRONICS catalogue, is used.

DISPOSAL:



To dispose of the product, abide by the local legislations regarding it.

GENERAL NOTES:



■ In accordance to the internal policy of constant quality improvement, ESA-PYRONICS reserves the right to modify the technical characteristics of the present document at any time and without warning.

■ It is possible to download technical sheets which have been updated to the latest revision from the **www.esa-pyronics.com** website.

■ The products manufactured by ESA-PYRONICS have been created in conformity to the **UNI EN 746-2:2010** Norms: Equipment for industrial thermal process - Part 2: Safety requirements for combustion and the movement and treatment of combustible elements. This norm is in harmony with the Machine Directive **2006/42/CE**. It is certified that the products in question respect all the requirements prescribed by the above mentioned Norms and Directives.

■ Certified in conformity with the **UNI EN ISO 9001** Norm by DNV GL.

CERTIFICATIONS:



EN88-1:2011 Pressure regulators and associated safety devices for gas appliances - Part 1: Pressure regulators for inlet pressures up to and including 50 kPa. Certificato **CE-51CP4479**



The products conform to the requests for the Euroasia market (Russia, Belarus and Kazakhstan).

CONTACTS / SERVICE:



Headquarters:

Esa S.p.A.
Via Enrico Fermi 40
24035 Curno (BG) - Italy
Tel +39.035.6227411
Fax +39.035.6227499
esa@esacombustion.it

International Sales:

Pyronics International s.a.
Zoning Industriel, 4ème rue
B-6040 Jumet - Belgium
Tel +32.71.256970
Fax +32.71.256979
marketing@pyronics.be

www.esapyronics.com

The BZR-REG-II pressure regulators have been designed according to the EN88/1 Norm and are ideal for applications with burners, gas mixers and proportional mixers as they allow fuel flow regulation and maintain the fuel/combustion agent ratio stable throughout the whole regulation range. The regulator is driven by a pressure signal that is proportional to the actual combustion air pressure and restores the same pressure value on the gas line. There is a version that can be used with gas up to 100°C.

APPLICATIONS

- Gas regulation on venturi mixers.
- Gas regulation on proportional mixers.
- Gas regulation on all types of burner feeding lines.

CHARACTERISTICS

BZR-REG-II STANDARD:

- Regulator group: 2
- Gas family: 1/2/3
- Maximum working pressure: 200 mbar [2.9 psi]
- Nominal working pressure: 80±200 mbar [1.1÷2.9 psi]
- Working temperature: -10°C÷60°C [14÷140°F]
- Maximum fluid temperature: 50°C [122°F]
- Flow ratio: 100:1
- Maximum differential pressure 36 mbar [0.5 psi]
- Maximum air signal: 70 mbar [1.0 psi]
- Minimum air signal: 0.4 mbar [0.06 psi]
- Precision: at low flow ±0.25 mbar [±0.036 psi]
at full flow ±0.76 mbar [±0.011 psi]
- Spring regulation field: +3 mbar/-5 mbar* [0.04÷-0.07 psi]
- Regulation ratio: 1:1

MATERIAL COMPOSITION:

- Valve body and seat: GAISI 9.1
- Valve disc: AISI303
- Bearing shaft: galvanized iron
- Diaphragms: Material approved according to EN549

BZR-REG-II-HT HIGH TEMPERATURE:

- Regulator group: 2
- Gas family: 1/2/3
- Maximum working pressure: 200 mbar [2.9 psi]
- Nominal working pressure: 80±200 mbar [1.1÷2.9 psi]
- Working temperature: -10°C÷60°C [14÷140°F]
- Maximum fluid temperature: 100°C [212°F]
- Flow ratio: 100:1
- Maximum differential pressure 36 mbar [0.5 psi]
- Maximum air signal: 70 mbar [1.0 psi]
- Minimum air signal: 0.4 mbar [0.06 psi]
- Precision: at low flow ±0.25 mbar [±0.036 psi]
at full flow ±0.76 mbar [±0.011 psi]
- Spring regulation field: +3 mbar/-5mbar* [0.04÷-0.07 psi]



- Regulation ratio: 1:1

MATERIAL COMPOSITION

- Valve body and seat: GAISI 9.1
- Valve disc: AISI303
- Bearing shaft: galvanized iron
- Diaphragms: Material approved according to EN549Tmax=200°C [392°F]

NB: *only at maximum flow

DESCRIPTION

The balanced modulators or “zero governors” reduce the fluid pressure to the atmospheric pressure or charge value. These units have two diaphragms:

- The first diaphragm, called balancing diaphragm, is meant to separate the inlet gas chamber of the valve body from the underlying chamber of the main diaphragm.
- The second diaphragm, called main diaphragm is meant to balance the outlet pressure existing in the underlying chamber of the diaphragm and the pressure existing in the upper chamber.

The spring on these regulators is needed to counterbalance the weight of the internal mobile parts and has an additional voltage which is just enough to close the valve. The upper chamber of the main diaphragm communicates with the atmosphere or the pilotage pressure. The lower chamber instead, communicates via a pulse hole with the regulated pressure chamber downstream the valve.

When there is a pressure difference between the upper chamber and lower chamber of the main diaphragm (positive pressure in the upper chamber caused by the pressure charge or drop in the lower chamber caused by the suction of a venturi mixer), the valve moves downwards thus allowing the gas to flow through the system.

The gas flow increases until the downstream pressure is equal to the existing pressure in the upper chamber; this is possible because the downstream pressure, via the pulse hole, is transmitted in the lower chamber of the diaphragm.

By altering the pilot pressure (charge or drop) an imbalance is caused between the existing pressures in the chambers. forcing the valve to open further until the system is rebalanced. The regulator design ensures precision throughout the entire flow range.

The BZR REG II regulators ensure a reliable and exact gas flow control for all types of combustion systems.

FLOWCHART

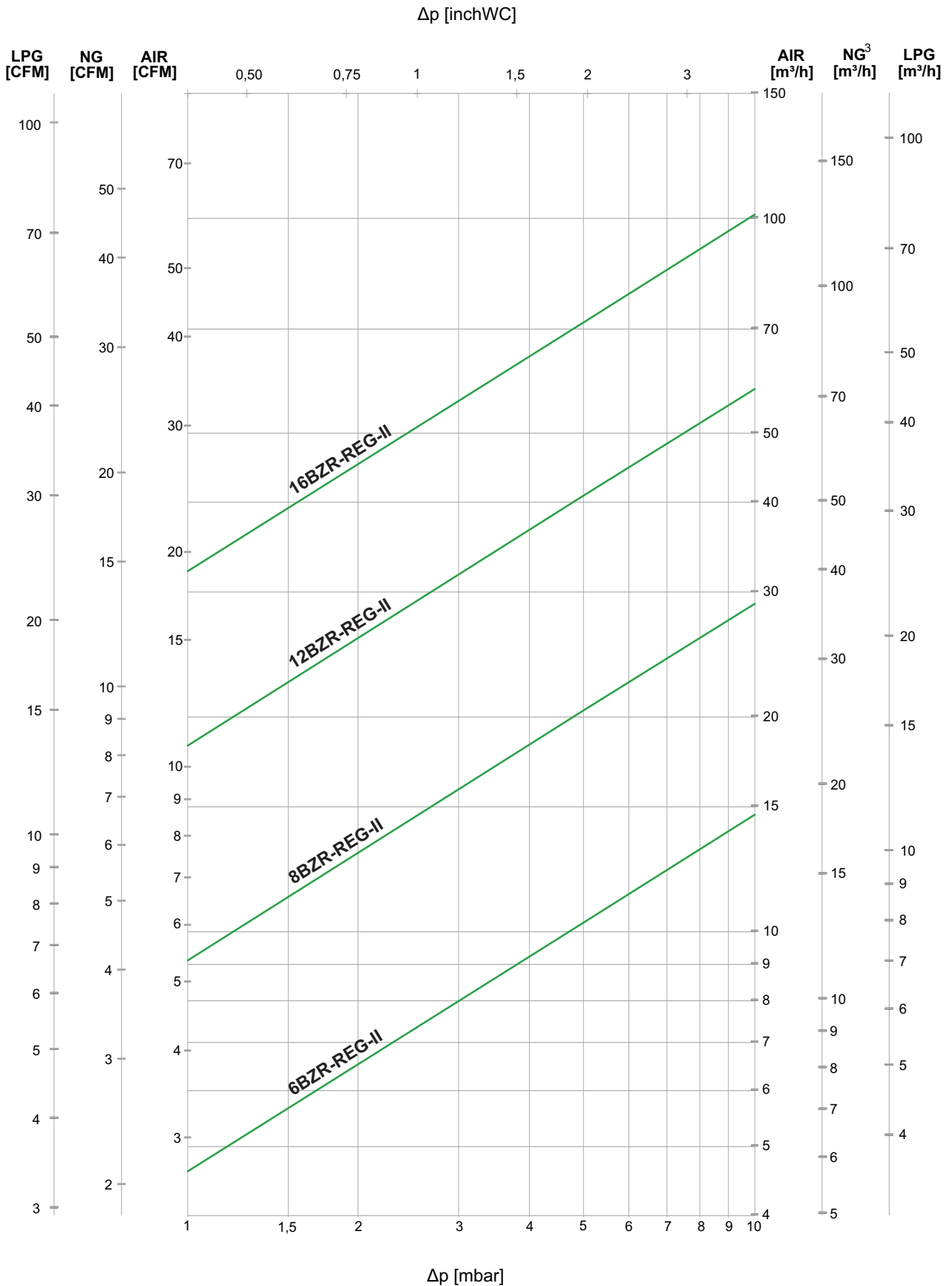

G5102I01

APPLICATION EXAMPLES

The BZR REG-II regulator is balanced when the gas pressure on the regulator outlet is the same as the loading pressure coming from the air line.

FIG. 01

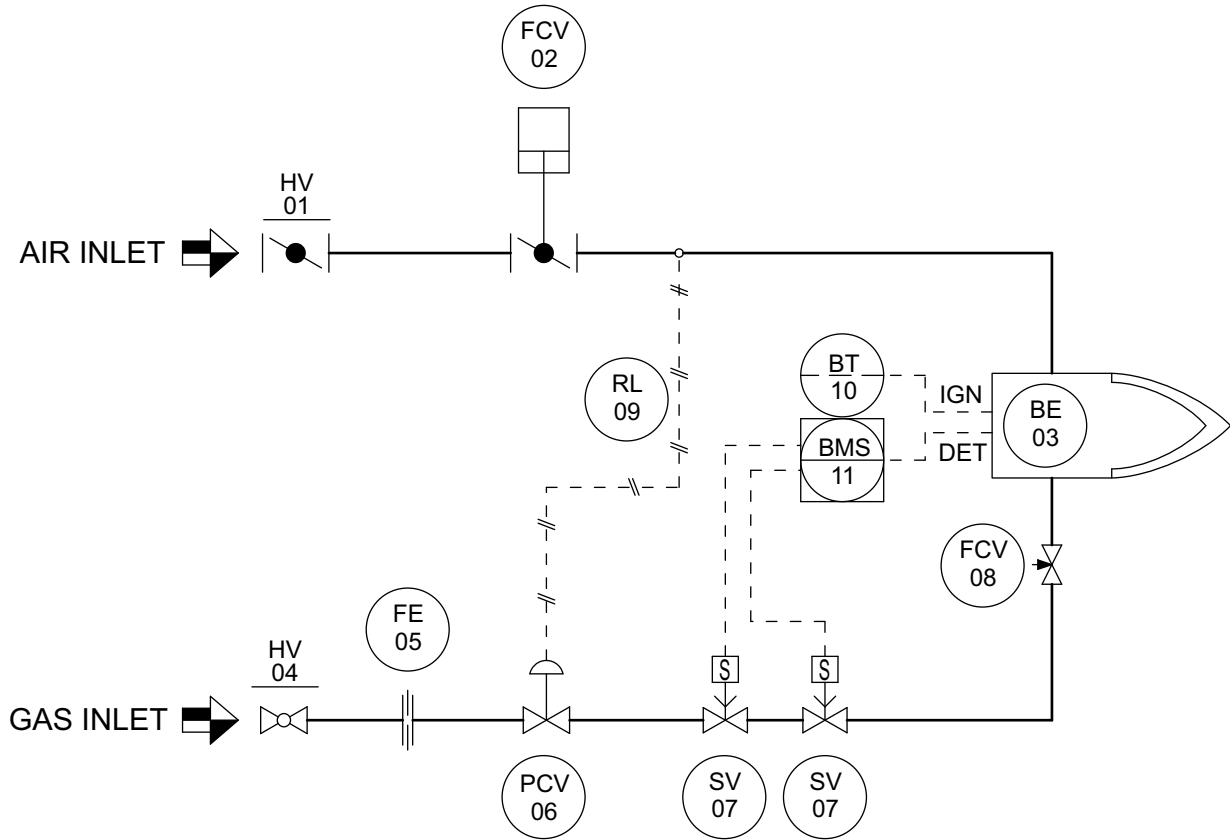

D5102I01

Tag	Position	Description
HV	1	Manual air interception valve
FCV	2	Motorized air valve
BE	3	Burner
HV	4	Manual gas interception valve
FE	5	Δp gas measurement calibrated orifice
FCV	6	Zero governor
SV	7	Safety solenoid valve
FCV	8	Gas limiting device
RL	9	Impulse line
BT	10	Ignition transformer
BMS	11	Flame control device

REMOTE CONTROL REGULATOR - BZR-REG-II-RC

Areas with very high ambient temperatures or placement of mixers in places that are difficult to reach, require very long piping between the gas pressure regulator and the mixer.

This results in problems such as reduced flow rates, delayed system responses and pressure drop along the pipeline to be considered in dimensioning the lines. In these cases a controller with remote control BZR-REG-II-RC is recommended.

The regulator with remote control works as a standard zero-governor, with the only difference that the regulator pulse hole is factory closed and the lower diaphragm chamber is connected to the pipe on a downstream section of the controller, close to the mixer (see fig.1).

Below is the flow scheme typical of a BZR-REG-II-RC pressure regulator:

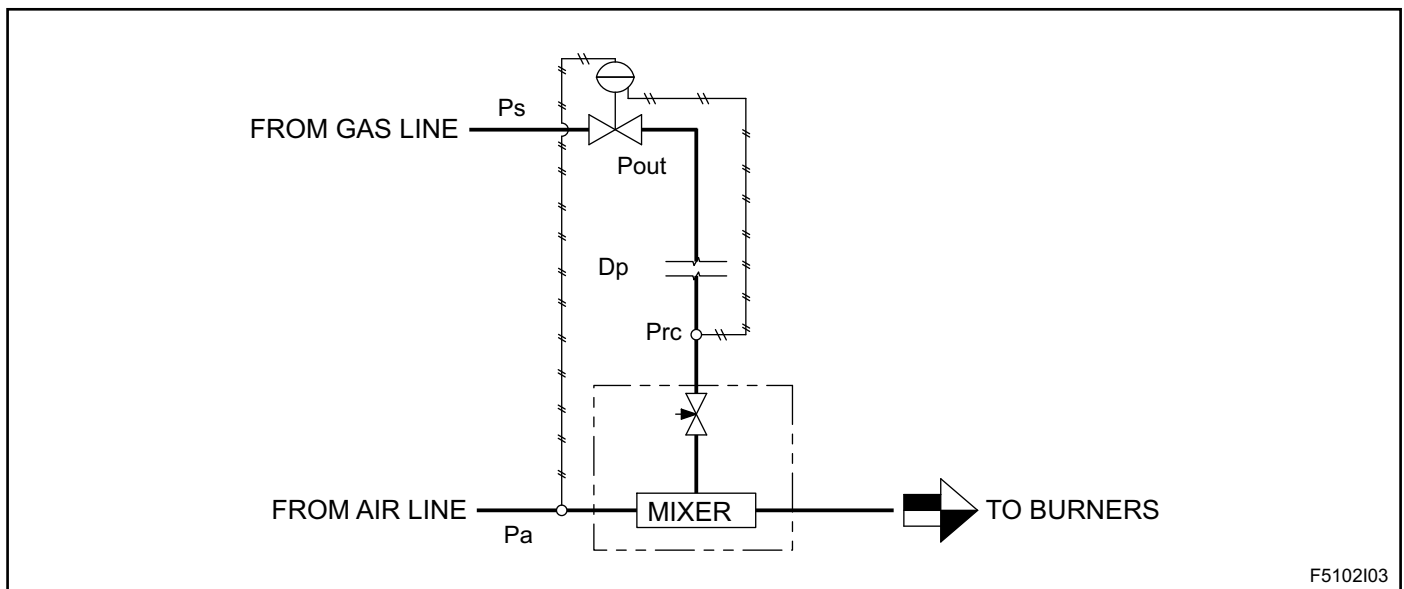
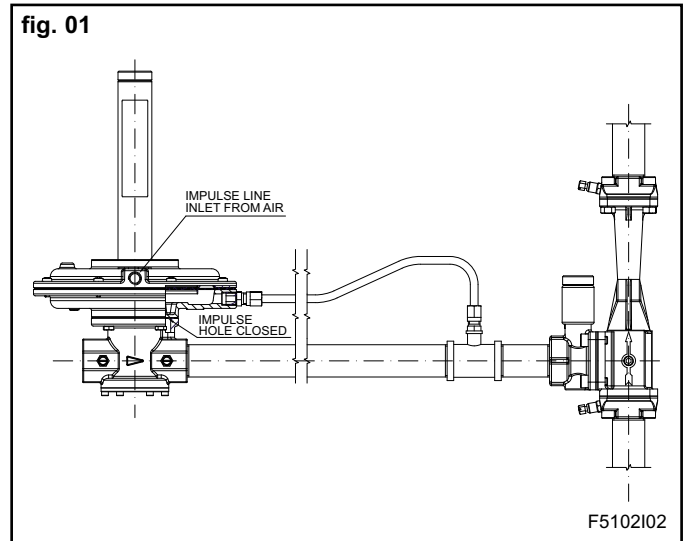

Said:

- Ps** = Input pressure to the pressure regulator
- Pa** = Loading pressure from the air pipe
- Dp** = Loss of load between controller and remote control position
- Pout** = Output pressure to the pressure regulator
- Prc** = Pressure controlled by the instrument, coming from the remote control

The downstream pressure of the remote control (Prc) is the same as using a standard unit and corresponds to the impulse loading pressure from the air line (Pa).

$Prc = Pa$

The regulator works correctly when the inlet pressure is higher than the output pressure of at least 10mbar.

$Ps = Pout + 10\text{mbar}$

When adjusting the pressure upstream of the regulator

and its impulse pressure, the pressure drop between the controller and the remote control pipe position must be taken into account.

$Pout = Prc + Dp$

Generally, note the loading pressure Pa, follow the following formula for calculating the required pressure upstream of the regulator:

$Ps = Pa + Dp + 10\text{mbar}$ [0.145 psi]

On the contrary, note the pressure upstream of the pressure regulator Ps, the maximum loading pressure to be applied to the regulator is:

$Pa = Ps - Dp - 10\text{mbar}$ [-0.145 psi]

Input pressure to the regulator and pulse loading pressure must not exceed certified values.

WARNINGS

All the BZR REG -II regulators, during the production phase, are subject to calibration and final inspection; being manufactured and assembled with specific criteria and very small tolerances, any kind of alteration or regulation made on field would prove to be counterproductive.

- Make sure that the working pressure and the fluid temperature are lower than the maximum allowed values.
- The pressure regulator does not have a filter. Make sure that upstream the regulator there is a filtering system that filters not more than 50 µm [0.002"].

- Check the correct installation of the valve before starting the flow in the pipe.

- In case of malfunctioning of the valve or actuator, follow the indications in the present manual in the "MAINTENANCE" chapter or contact ESA-PYRONICS technical service

- Any modification or repair done by third parties could compromise the application safety and will cause the warranty conditions to automatically expire.

INSTALLATION

1 - The correct working position is vertical with piping placed horizontally on a flat surface. Horizontal mounting with vertical piping is also allowed.

2 - The arrow on the valve bodies indicates the flow direction.

3 - The regulators must not be installed in areas with temperatures higher than the maximum working temperature value.

4 - For installation on the piping, use tapered threads according to ISO7/1, using opportune thread seal pastes.

5 - Make sure there is a part of the piping upstream and downstream the regulator of at least 100mm [4"].

6 - For the connection of the regulator pulse signals, use metallic pipes with an internal section of at least 8mm. Check that the piping has not been crushed, flattened or deformed as this could affect the correct transmission of the instrument's signal.

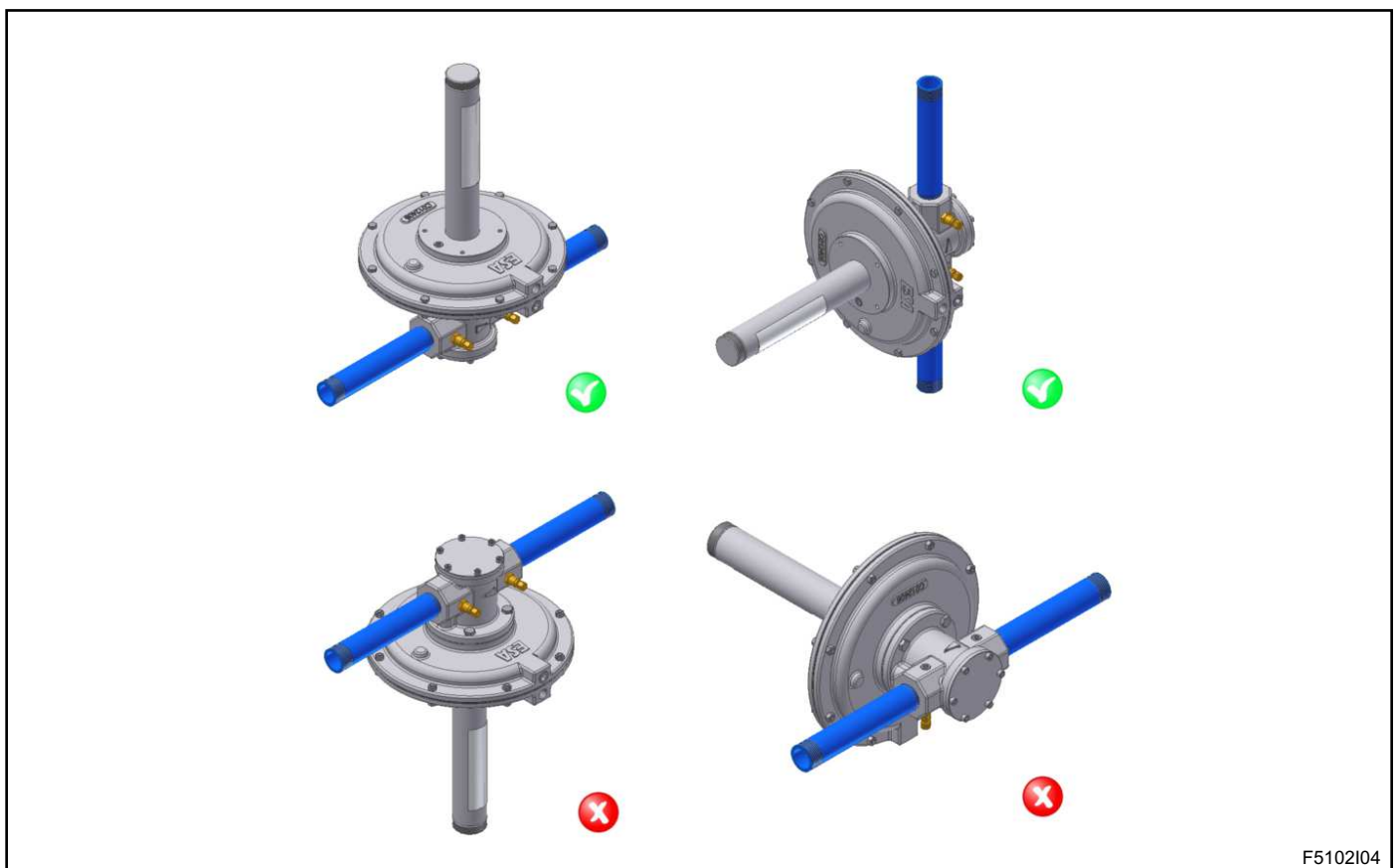

F5102104

SETTING AND REGULATION

During the production phase, all the BZR REG-II regulators are set with neutral calibration: given a loading pressure the spring is regulated to have the same outlet pressure on the regulator.

To modify the setting, follow the instructions below:

1 - Open the closing cap of the stem where the regulation screw is housed.

2 - For correct calibration of the air/gas ratio to the mini-

mum power, act on the regulation spring screw respecting the following modalities:

a) screw on the regulation screw to increase the outlet pressure of the instrument.

b) unscrew the regulation screw to decrease the outlet pressure of the instrument.

3 - after regulation, put the closing cap back in its place, making sure that it is screwed on tightly again to guarantee the tightness towards the outside.

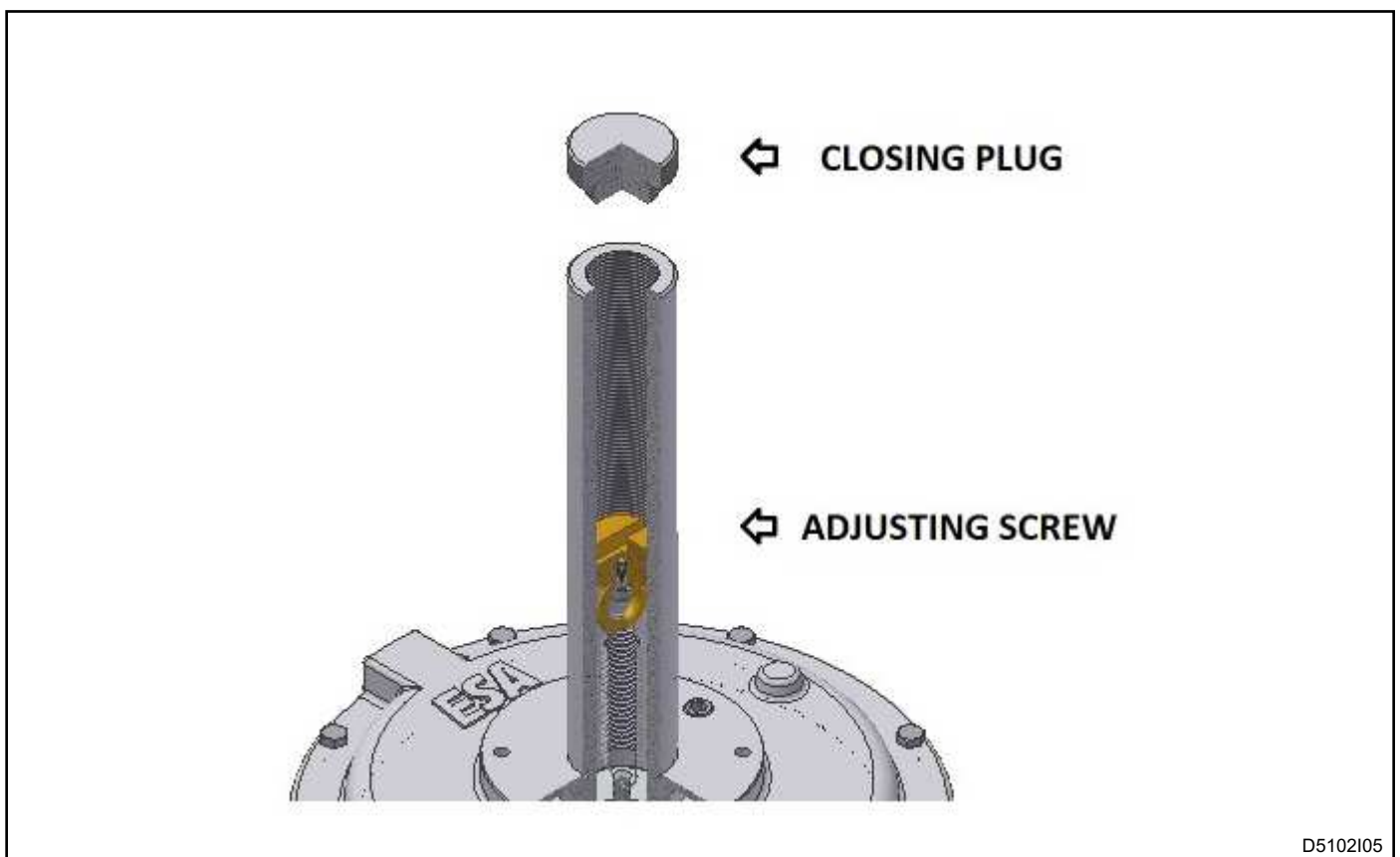

MAINTENANCE

It is not possible to repair the regulators or their components. Repair must be done by qualified ESA-PYRONICS staff according to the norms in force.

For each type of setting or repair you are strongly advised to contact ESA-PYRONICS.

OVERALL DIMENSIONS - BZR-REG-II

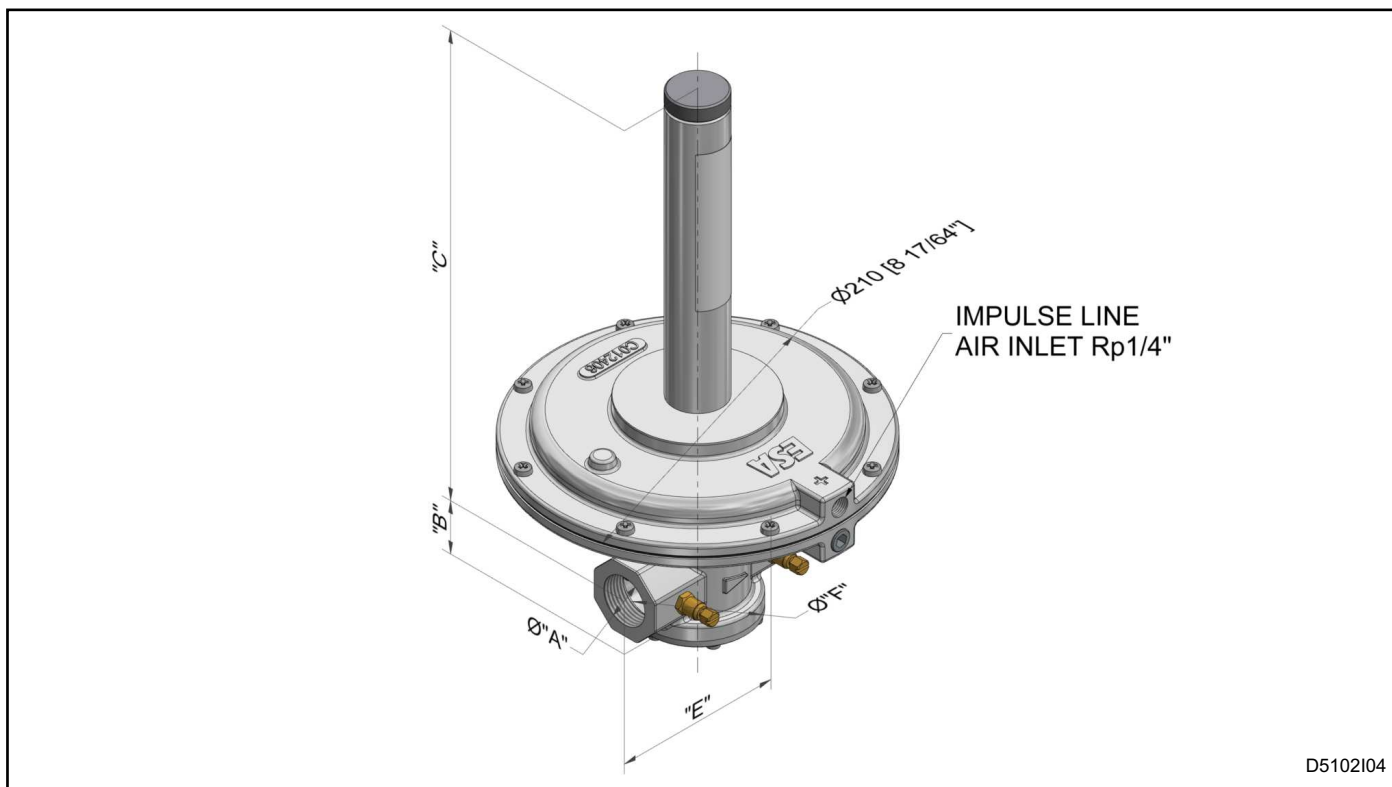

Model	Gas Ø A	B		C		E		F Ø		Weight	
		[mm]	[inch]	[mm]	[inch]	[mm]	[inch]	[mm]	[inch]	[Kg]	[lbs]
6 BZR-REG-II	Rp 3/4"	36	1.27/64	300	11.13/16	108	4.1/4	70	2.3/4	2,75	6.06
8 BZR-REG-II	Rp 1"	36	1.27/64	300	11.13/16	108	4.1/4	70	2.3/4	2,75	6.06
12 BZR-REG-II	Rp 1.1/2"	57	2.1/4	308	12.1/8	140	5.33/64	85	3.11/32	4,2	9.25
16 BZR-REG-II	Rp 2"	62	2.7/16	316	12.7/16	168	6.39/64	85	3.11/32	4,25	9.36

ORDERING CODE - REGULATOR



MODEL		01
6	6	
8	8	
12	12	
16	16	

02		VERSION
Standard		
High Temperature		HT
Remote control		RC