

Accessories



Air/gas ratio control valve

AR-REG-II (E5103 rev. 02 - 28/07/2015)

GENERAL WARNINGS:



■ All installation, maintenance, ignition and setting must be performed by qualified staff, respecting the norms present at the time and place of the installation.

■ To avoid damage to people and things, it is essential to observe all the points indicated in this handbook. The reported indications do not exonerate the Client/User from observing general or specific laws concerning accidents and environmental safeguarding.

■ The operator must wear proper DPI clothing (shoes, helmets...) and respect the general safety, prevention and precaution norms.

■ To avoid the risks of burns or high voltage electrocution, the operator must avoid all contact with the burner and its control devices during the ignition phase and while it is running at high temperatures.

■ All ordinary and extraordinary maintenance must be performed when the system is stopped.

■ To assure correct and safe use of the combustion plant, it is of extreme importance that the contents of this document be brought to the attention of and be meticulously observed by all personnel in charge of controlling and working the devices.

■ The functioning of a combustion plant can be dangerous and cause injuries to persons or damage to equipment. Every burner must be provided with certified combustion safety and supervision devices.

■ The burner must be installed correctly to prevent any type of accidental/undesired heat transmission from the flame to the operator or the equipment.

■ The performances indicated in this technical document regarding the range of products are a result of experimental tests carried out at ESA-PYRONICS. The tests have been performed using ignition systems, flame detectors and supervisors developed by ESA-PYRONICS. The respect of the above mentioned functioning conditions cannot be guaranteed if equipment, which is not present in the ESA-PYRONICS catalogue, is used.

DISPOSAL:



To dispose of the product, abide by the local legislations regarding it.

GENERAL NOTES:



■ In accordance to the internal policy of constant quality improvement, ESA-PYRONICS reserves the right to modify the technical characteristics of the present document at any time and without warning.

■ It is possible to download technical sheets which have been updated to the latest revision from the **www.esapyronics.com** website.

■ The products manufactured by ESA-PYRONICS have been created in conformity to the **UNI EN 746-2:2010** Norms: Equipment for industrial thermal process - Part 2: Safety requirements for combustion and the movement and treatment of combustible elements. This norm is in harmony with the Machine Directive **2006/42/CE**. It is certified that the products in question respect all the requirements prescribed by the above mentioned Norms and Directives.

■ Certified in conformity with the **UNI EN ISO 9001** Norm by DNV GL.

CERTIFICATIONS:



EN88/1:2011 Pressure regulators and associated safety devices for gas appliances - Part 1: Pressure regulators for inlet pressures up to and including 50 kPa.
Certificate **CE-51CQ4633**

CONTACTS / SERVICE:



ESA S.p.A.
Via Enrico Fermi 40
24035 Curno (BG) - Italy
Tel +39.035.6227411
Fax +39.035.6227499
esa@esacombustion.it

ESA Belgium
Zoning Industriel, 4ème rue
B-6040 Jumet - Belgium
Tel +32.71.256970
Fax +32.71.256979
marketing@pyronics.be

www.esapyronics.com

The AR-REG-II balanced modulators reduce fluid pressure to a charging pressure value, guaranteeing a constant ratio between fuel and combustion agents, resulting in more efficient combustion reducing consumption. As opposed to traditional ratio regulators, the AR-REG-II operates installed on the combustion air pipeline and is modulated by a pressure signal coming from the fuel gas line.

APPLICATIONS

- Fuel/combustion air ratio regulation
- Revamping of combustion systems from modulated fixed air/gas to Stoichiometric ratio,

CHARACTERISTICS

- Regulation group: 2
- Gas Group 1/2/3
- Maximum working pressure: 200mbar
- Nominal working pressure: 70÷200mbar
- Working temperature: -10°C ÷ 70°C
- Maximum air temperature: 200°C
- Flow ratio: 10:1
- Maximum gas signal: 70 mbar
- Nominal gas signal: 50 mbar
- Minimum gas signal: 0,4 mbar
- Precision: low flow +0,0 / -0,1 mbar
full flow +0,0 / -1,0 mbar
- Spring regulation field: -5 mbar/ +5mbar
- Spring regulation field ($P_{in}=70\text{mbar}$): -5mbar / 0mbar

MATERIAL COMPOSITION:

- Valve seat body: GAISI 9.1
- Valve disc AISI303
- Main spindle galvanized iron
- Diaphragms HTmaterial approved according to EN549

DESCRIPTION

The AR series modulators are double diaphragm units in which the first, known as balancing diaphragm, separates the air inlet chamber of the valve body from the underlying chamber of the main diaphragm; and the second diaphragm balances the output pressure existing in the lower chamber of the actual diaphragm and the existing pressure in the upper chamber.

The spring of these regulators is meant to counterbalance the weight of the moving internal parts and has an added tension just enough to close the valve.

The small sealing diaphragm is sized so that its surface is equal to the actual area of the valve disc so that the variations in the supply pressure are cancelled by the effects of the position of the valve. The upper chamber of the main diaphragm is in communication with the pilot pressure, while the lower chamber is in communication, by means of an impulse orifice, with the chamber of the



F5103103



F5103103

regulated pressure downstream of the valve. With equal pressures in both chambers above and below the main diaphragm, the valve is closed; when you create a pressure difference between the upper chamber and the lower (positive pressure in the upper chamber due to the charge), the valve will move downward thus allowing the air to flow through the system. If the air flow increases until the

DESCRIZIONE

downstream pressure equals the pressure in the upper chamber; this is possible because the downstream pressure, through the pulse hole, is transmitted in the lower chamber of the diaphragm. The AR regulators ensure flow-reliable and accurate air flow control for all types of combustion systems.

In case of installations on roller on fixed modulated air and gas roller kilns:

- Simple installation on air line
- Maintaining existing plant configuration without changing the combustion head.
- Ability to adjust the excess air manually on each burner.
- Stoichiometry of the combustion constant during the modulation phases from minimum to maximum flow rate.
- Energy saving up to 10%.

FLOW CHART

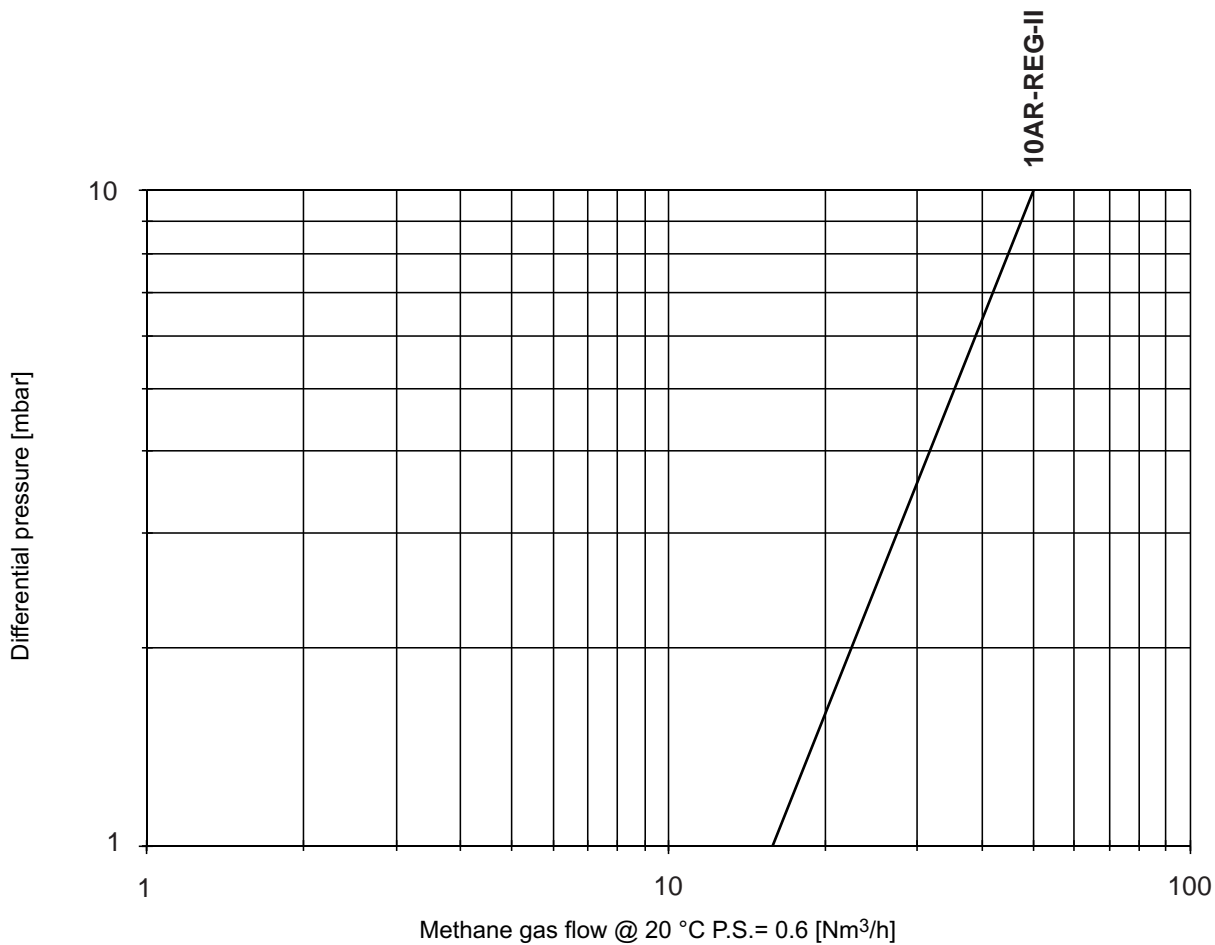

G5103101

APPLICATION EXAMPLES

The AR controller is balanced when the air pressure at the controller output is equal to the loading pressure of the gas coming from the line.

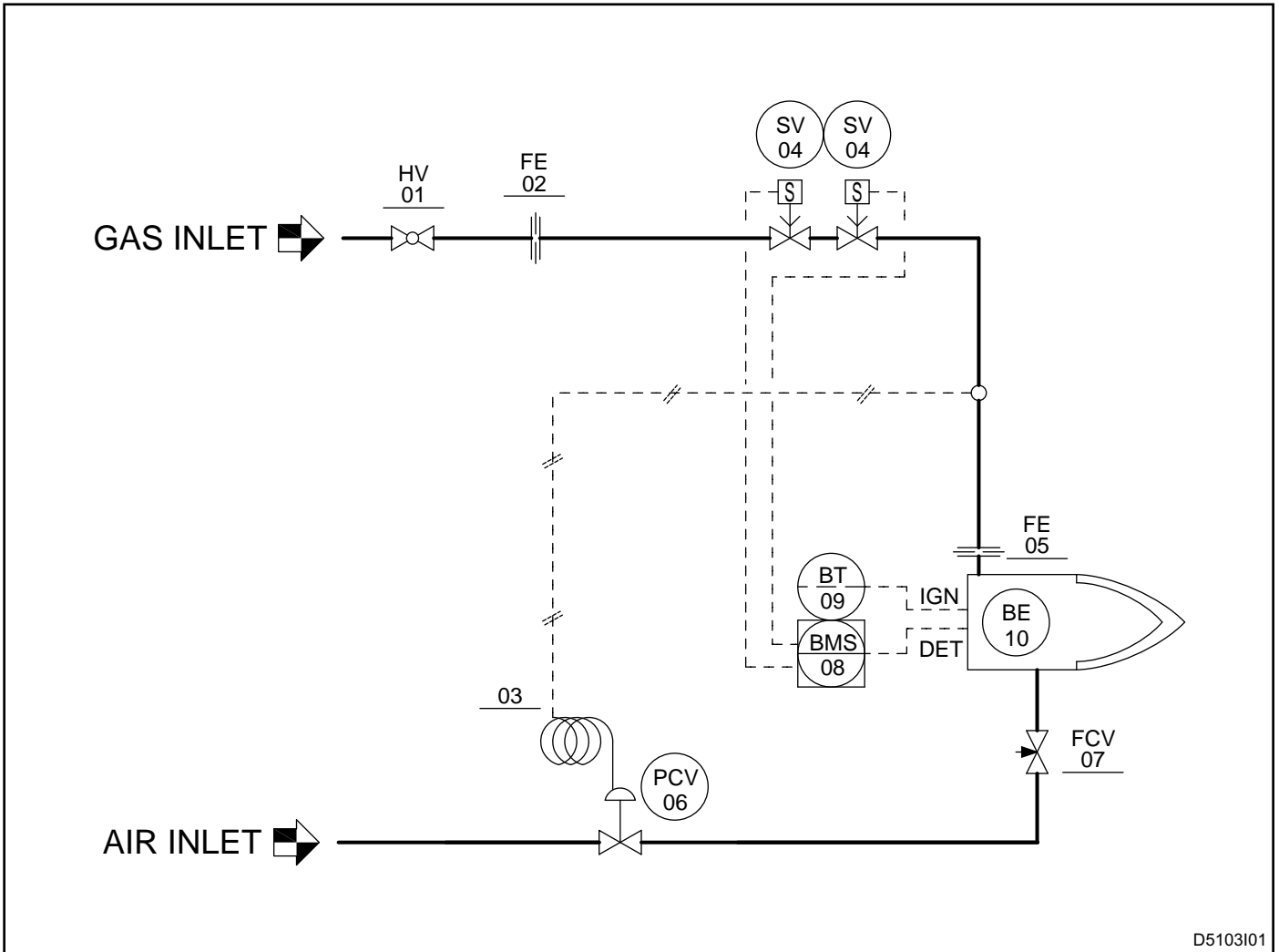

D5103101

Pos.	Description	Included	Not included
1	Gas ball valve		X
2	Calibrated gas flange		X
3	Impulse line		X
4	Safety solenoid valve		X
5	Calibrated gas orifice *		X
6	Pressure regulator	X	
7	Manual air regulation valve		X
8	Flame control		X
9	Ignition transformer		X
10	Burner		X

* NB: For proper function of the regulator it is necessary to install a calibrated orifice on the gas inlet.

WARNINGS

All the AR regulators, in the production phase, are subjected to functional testing and calibration; being built and fitted with special criteria and very small tolerances, any modification or adjustment made in the field would be counterproductive. For each type of calibration or repair please contact ESA.

- Make sure that the pressure and the temperature of the fluid are less than the maximum allowed.
- The pressure regulator is not equipped with a filter. Ensure that upstream of the regulator there is a filter system with filtration of not more than 50 µm.

- Check the correct installation of the valve before starting the flow in the pipeline.
- In case of malfunction of the valve or actuator, follow the instructions of this manual in the chapter "MAINTENANCE" or contact your ESA PYRONICS service.
- Any modification or repair done by third parties can compromise the application safety and automatically voids the warranty conditions.
- After each adjustment of the adjusting screw, make sure that the protection cap is fully tightened in the closed position, so as to ensure the tightness towards the outside.

INSTALLATION

- 1 - The correct working position is vertical with flat plane horizontal piping. horizontal assembly with vertical piping is allowed.
- 2 - The arrow on the valve body indicates the flow direction
- 3 - Regulators should not be installed in areas with a temperature above the maximum operating value.
- 4 - For installation in the pipeline, provide tapered threads according to ISO 7/1, using appropriate thread sealing paste.

- 5 - Provide a section of pipe upstream and downstream of the regulator at least 100mm.
- 6 - With regards to the connection of the regulator's impulse signals, use metallic pipes with an internal section of at least $\varnothing 8$ mm. Check that there are no signs of squashing or deformation along the pipes as this could affect the proper transmission of the signal to the instrument.

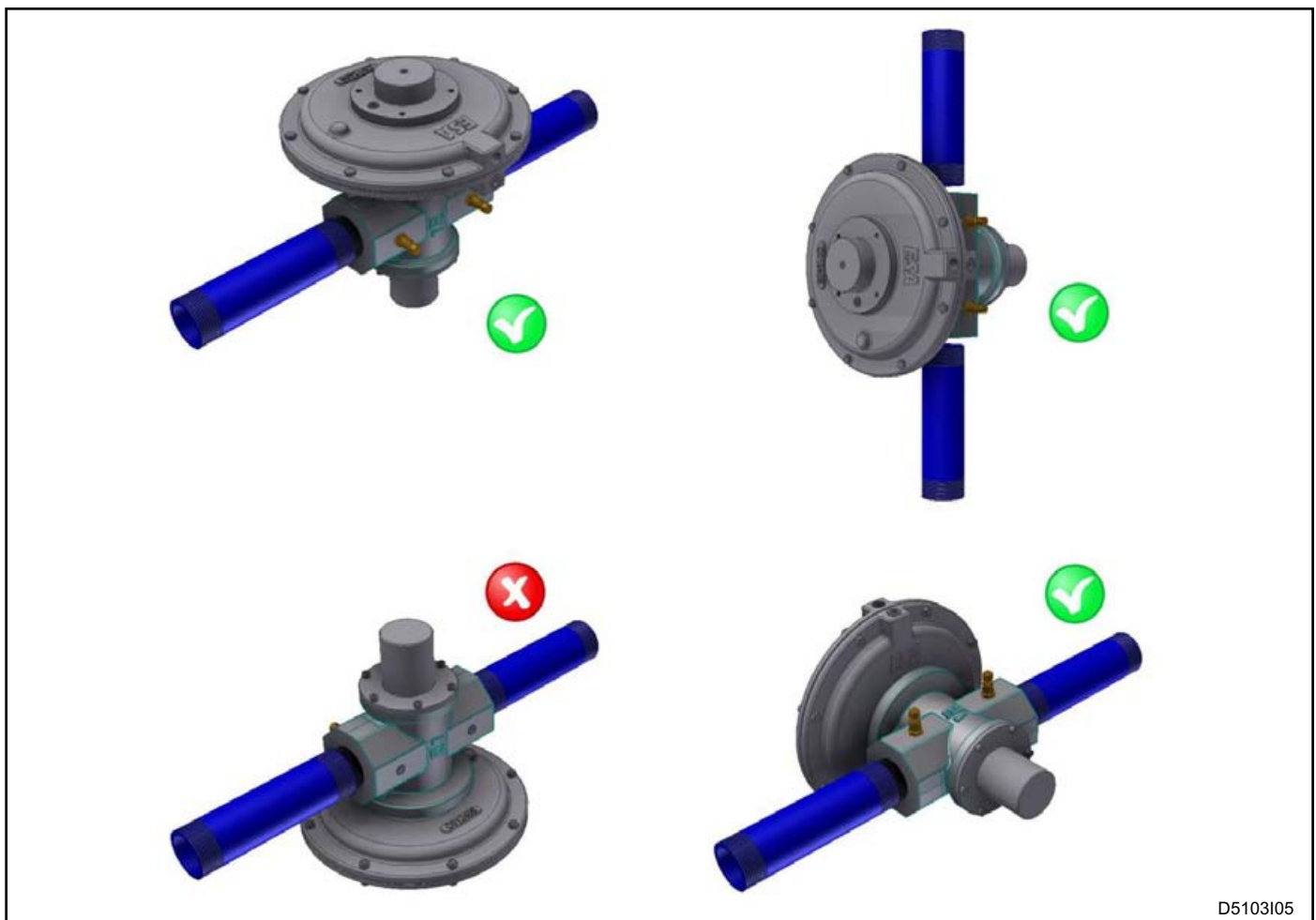

D5103I05

REGULATION AND SETTING

All AR-REG-II combustion ratio regulators, during the production phase, are subject to functional setting and inspection; as they are built with special criteria and very small tolerances.

1 - Open the cap of the stem where an adjusting screw is housed

2 - For a correct calibration of the air / gas ratio at minimum power, turn the spring as follows:

- a)** screw on the adjustment screw to decrease the output pressure of the instrument.
- b)** unscrew the adjusting screw to increase the output pressure of the instrument..

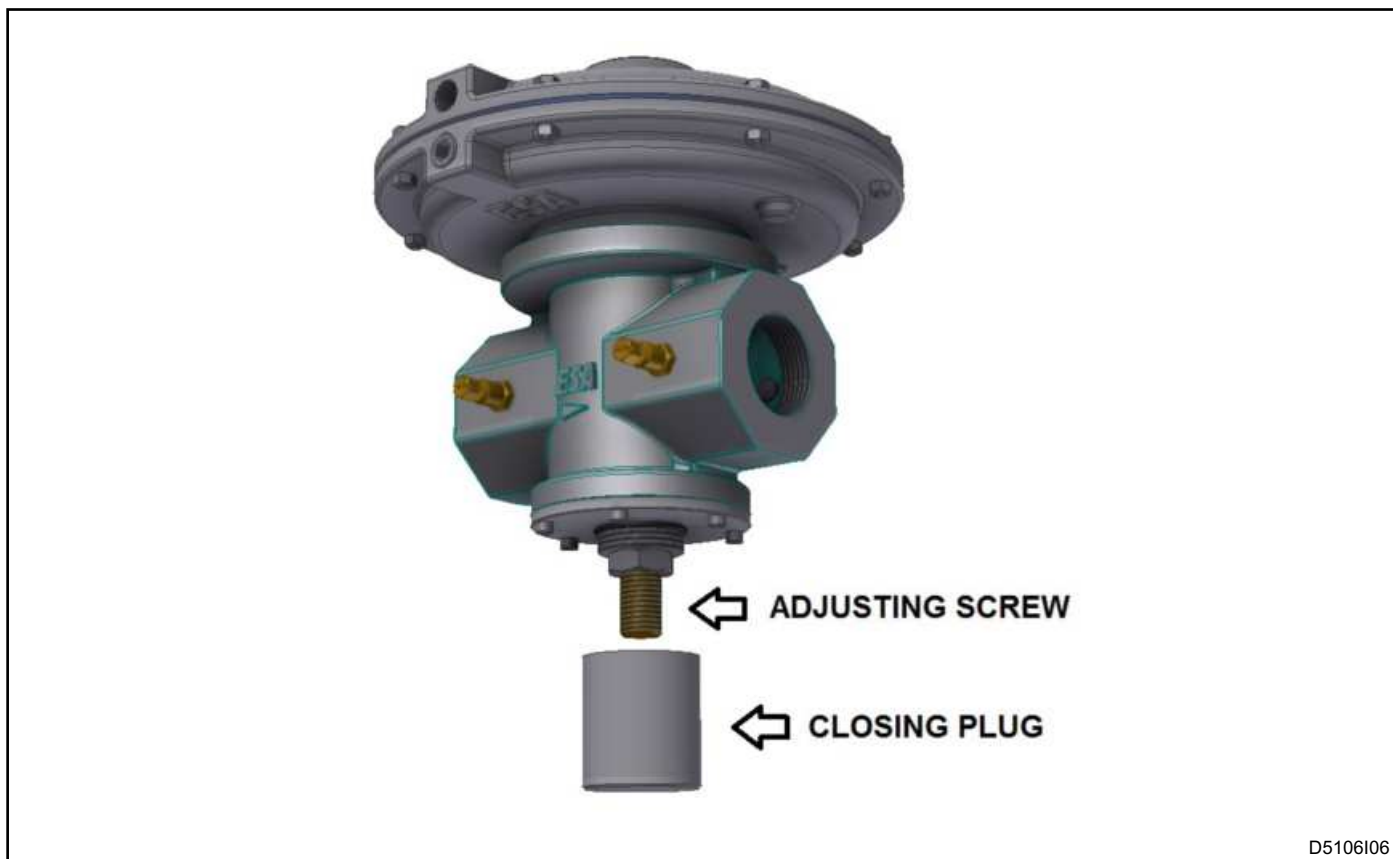

D5106106

MAINTENANCE

You cannot perform repairs on the regulators or on its components. Repair must be performed by ESA S.p.A. qualified technicians respecting the norms in force. . Per

ogni tipo di taratura o di riparazione si consiglia vivamente di contattare il personale ESA PYRONICS.

DIMENSIONI DI INGOMBRO - REGOLATORE AR-REG-II

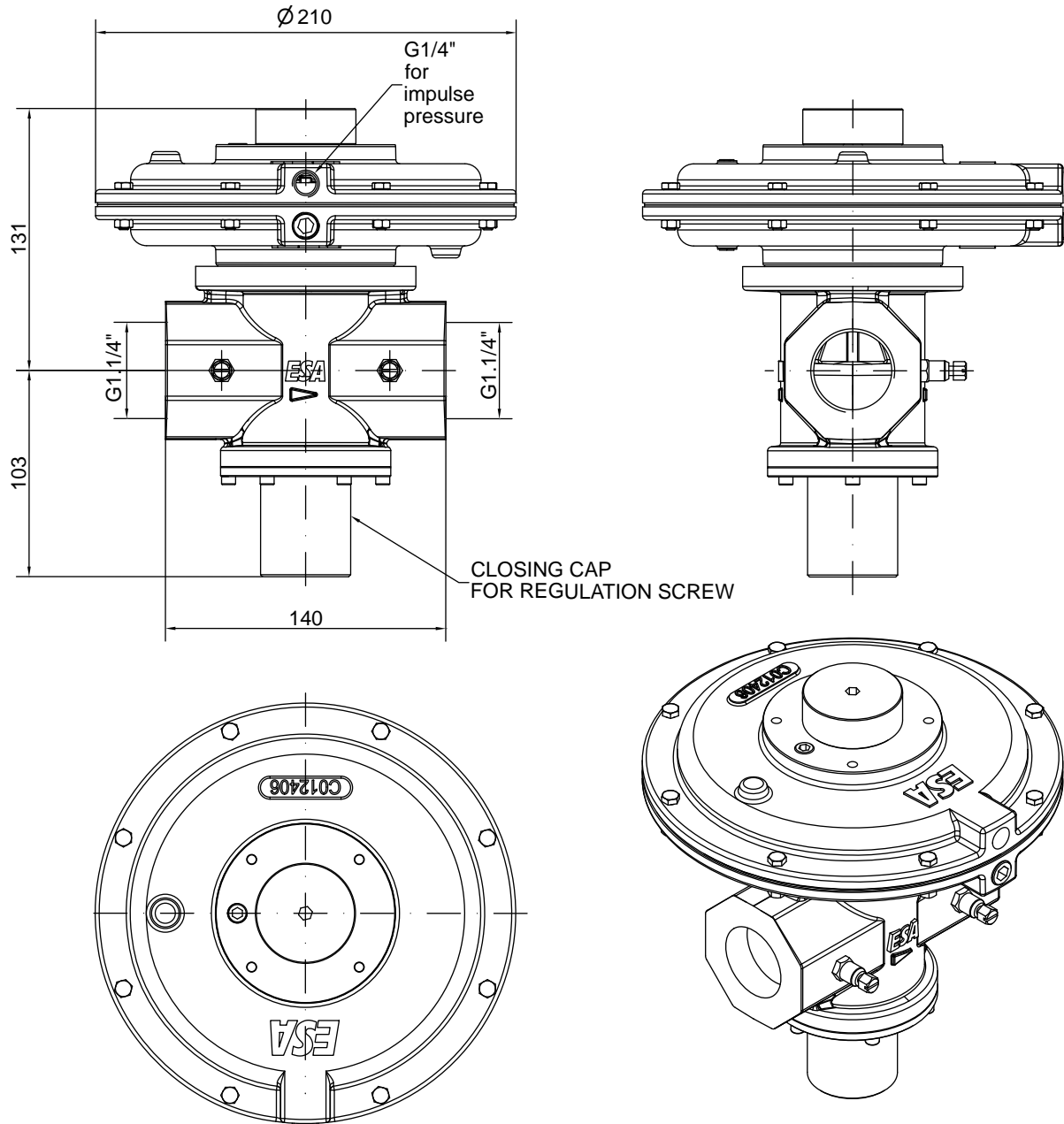

D5103I02