

Accessories

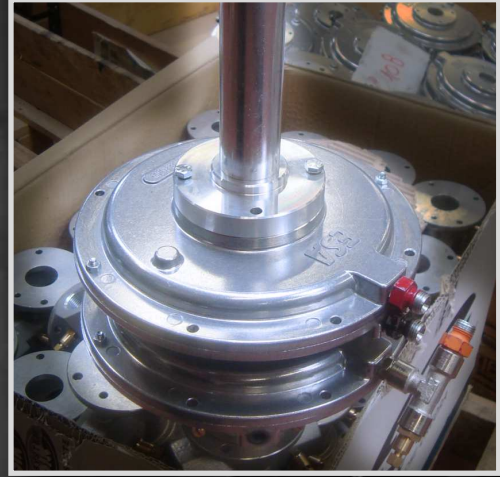
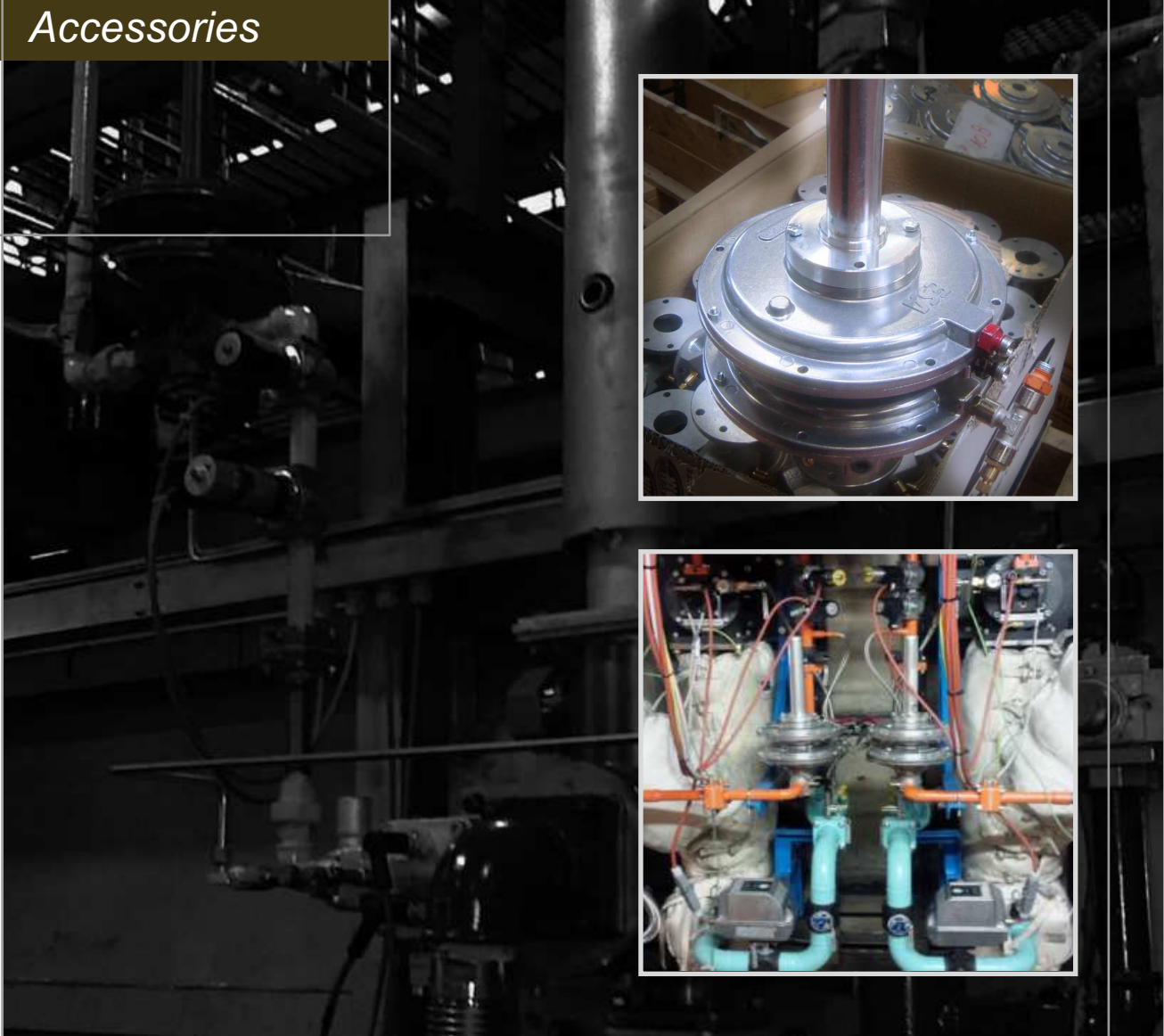

Combustion ratio regulators

FCR-REG-II (E5106 rev. 02 - 13/05/2019)

GENERAL WARNINGS:



■ All installation, maintenance, ignition and setting must be performed by qualified staff, respecting the norms present at the time and place of the installation.

■ To avoid damage to people and things, it is essential to observe all the points indicated in this handbook. The reported indications do not exonerate the Client/User from observing general or specific laws concerning accidents and environmental safeguarding.

■ The operator must wear proper DPI clothing (shoes, helmets...) and respect the general safety, prevention and precaution norms.

■ To avoid the risks of burns or high voltage electrocution, the operator must avoid all contact with the burner and its control devices during the ignition phase and while it is running at high temperatures.

■ All ordinary and extraordinary maintenance must be performed when the system is stopped.

■ To assure correct and safe use of the combustion plant, it is of extreme importance that the contents of this document be brought to the attention of and be meticulously observed by all personnel in charge of controlling and working the devices.

■ The functioning of a combustion plant can be dangerous and cause injuries to persons or damage to equipment. Every burner must be provided with certified combustion safety and supervision devices.

■ The burner must be installed correctly to prevent any type of accidental/undesired heat transmission from the flame to the operator or the equipment.

■ The performances indicated in this technical document regarding the range of products are a result of experimental tests carried out at ESA-PYRONICS. The tests have been performed using ignition systems, flame detectors and supervisors developed by ESA-PYRONICS. The respect of the above mentioned functioning conditions cannot be guaranteed if equipment, which is not present in the ESA-PYRONICS catalogue, is used.

DISPOSAL:



To dispose of the product, abide by the local legislations regarding it.

GENERAL NOTES:



■ In accordance to the internal policy of constant quality improvement, ESA-PYRONICS reserves the right to modify the technical characteristics of the present document at any time and without warning.

■ It is possible to download technical sheets which have been updated to the latest revision from the **www.esa-pyronics.com** website.

■ The products manufactured by ESA-PYRONICS have been created in conformity to the **UNI EN 746-2:2010** Norms: Equipment for industrial thermal process - Part 2: Safety requirements for combustion and the movement and treatment of combustible elements. This norm is in harmony with the Machine Directive **2006/42/CE**. It is certified that the products in question respect all the requirements prescribed by the above mentioned Norms and Directives.

■ Certified in conformity with the **UNI EN ISO 9001** Norm by DNV GL.

CERTIFICATIONS:



EN88/1:2011 Pressure regulators and associated safety devices for gas appliances - Part 1: Pressure regulators for inlet pressures up to and including 50 kPa. Certificato **CE-51CP4479**



The products conform to the requests for the Euroasia market (Russia, Belarus and Kazakhstan).

CONTACTS / SERVICE:



Headquarters:

Esa S.p.A.
Via Enrico Fermi 40
24035 Curno (BG) - Italy
Tel +39.035.6227411
Fax +39.035.6227499
esa@esacombustion.it

International Sales:

Pyronics International s.a.
Zoning Industriel, 4ème rue
B-6040 Jumet - Belgium
Tel +32.71.256970
Fax +32.71.256979
marketing@pyronics.be

www.esapyronics.com

The FCR-REG-II combustion ratio regulators have been created to allow fuel flow control on combustion plants that are fed by preheated air or in combustion chambers having variable pressure. The regulator is piloted by a differential pressure signal, that is proportional in every operating condition, to the actual flow of combustion air which is detected by a measuring flange placed on the cold air pipeline.

APPLICATIONS

- Combustion ratio regulation on preheated air plants (FCR-REG-II-STD/RMT).
- Modulator piloting on preheated air plants (FCR-REG-II-PC).
- Ratio regulators in variable pressure combustion chambers.
- Ratio regulators with variable section premix burners.

CHARACTERISTICS

- | | |
|---|------------------|
| ■ Regulator group: | 2 |
| ■ Gas family: | 1/2/3 |
| ■ Maximum operating pressure: | 200mbar |
| ■ Nominal operating pressure: | 70÷200mbar |
| ■ Operating temperature: | -10°C ÷ 60°C |
| ■ Flow ratio: | 10:1 |
| ■ Max. air Δp signal: | 36 mbar |
| ■ Normal air Δp signal: | 25 mbar |
| ■ Minimum air Δp signal: | 0,4 mbar |
| ■ Precision at low capacity: | +0,0 / -0,1 mbar |
| ■ Precision at full capacity: | +0,0 / -1,0 mbar |
| ■ For remote version (RMT) Δp gas signal: | 0,4 ÷ 36 mbar |
| ■ Spring regulation field: | -6 mbar/ +6mbar |
| ■ Regulation ratio: | 1:1 |

MATERIAL COMPOSITION:

- | | |
|------------------------|--------------------------------|
| ■ Valve seat and body: | GAISI 9.1 |
| ■ Valve disc: | AISI303 |
| ■ Main shaft: | galvanized steel |
| ■ Diaphragm: | material approved by the EN549 |

DESCRIPTION

The FCR-REG-II regulator is piloted with the Δp of a POP calibrated orifice (see E5021 / E5719 / E5720 data sheets) placed on the air line. This differential pressure applied on the upper diaphragm, is balanced when the fluid pressure on the regulator outlet takes on the same Δp value compared with the atmospheric pressure found in the upper part of the diaphragm;

You can use a Δp charged regulator also on the lower membrane, compensating the Δp air signal obtained by appropriately regulating a GAF gas limiting device (see data sheet E1601) if there are large pressure variations on the combustion chamber, instead of venting into the



atmosphere, the upper side of the second diaphragm can be connected to the actual chamber via special reference line. This will stabilize the gas supply to the burner.

The FCR ratio regulator also has three small diaphragms to balance dynamic and statistic forces that constitute the control system.

If the regulator is applied on a combustion air preheating system, it maintains the air/fuel ratio constant from the start when it is cold until operation with hot air.

All the air/gas control components are assembled in the cold area of the system, thus reducing maintenance costs.

FLOW CHART

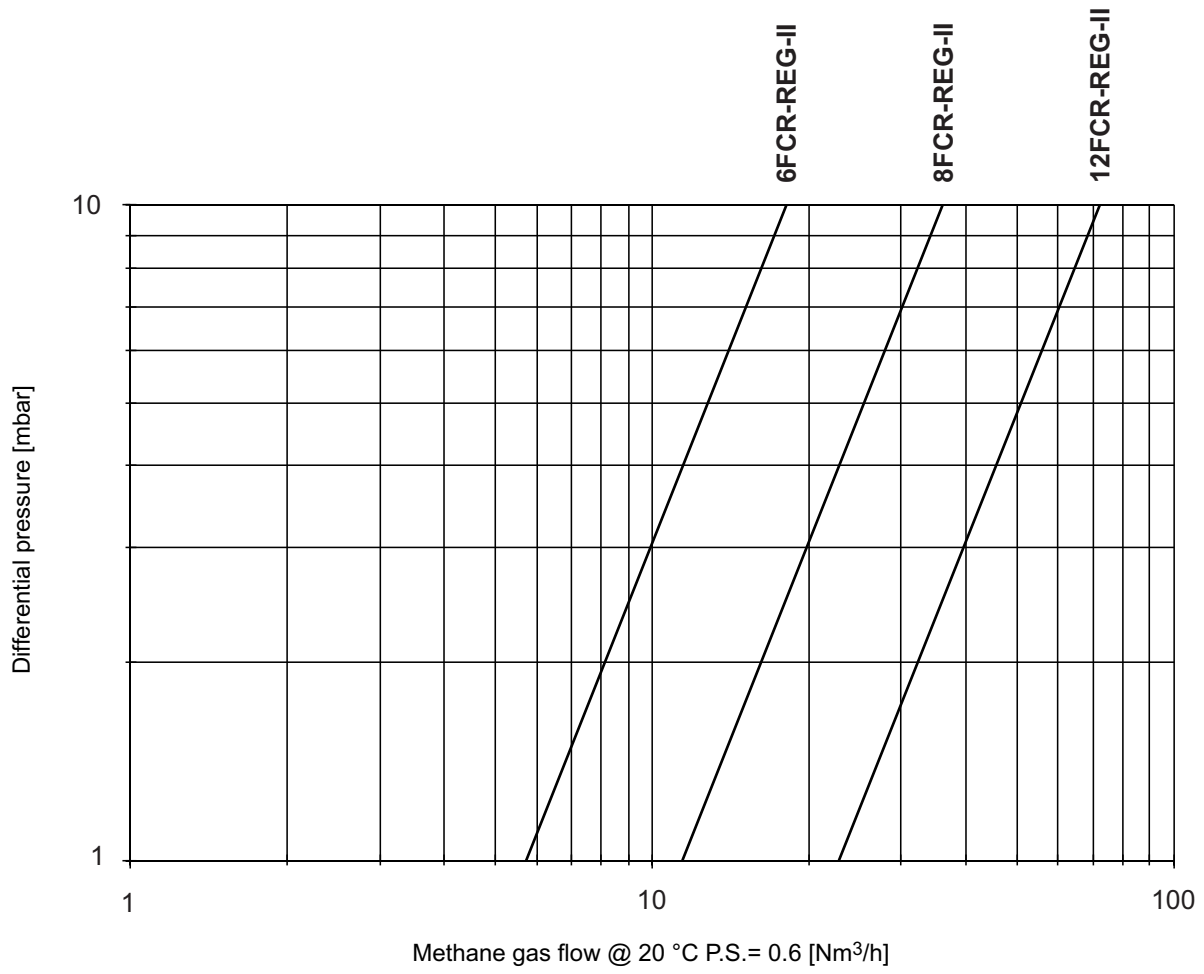

G5106101

APPLICATION EXAMPLES - FCR-REG-II-STD

In the standard applications, the FCR-REG-II-STD ratio regulator is loaded with a calibrated flange Δp which is present on the air line.

The regulator is balanced when the outlet gas pressure is the same as the differential pressure piloted by the air flange.

FIG. 01

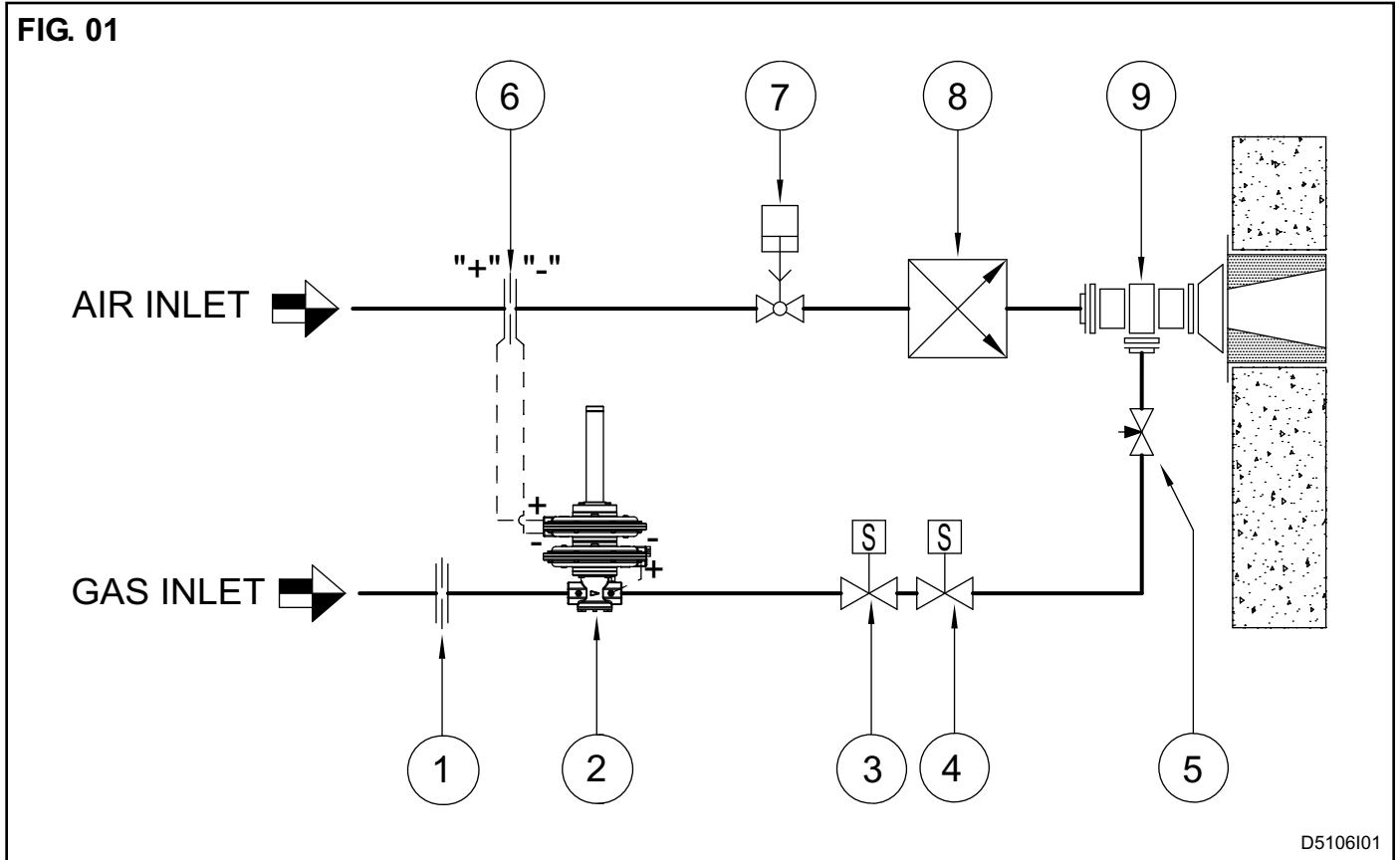

D5106I01

Position	Description
1	Δp gas measuring calibrated flange
2	Air/gas ratio regulator
3	Solenoid valve
4	Solenoid valve
5	Gas passage limiting device
6	Δp air measuring calibrated flange
7	Air flow regulation valve
8	Heat exchanger
9	Burner

ESEMPI DI APPLICAZIONE - FCR-REG-II-RMT

When the gas pressure regulator outlet is not enough to feed the burner at maximum capacity, it can load the lower chamber of the regulator with the only differential

pressure taken upstream and downstream of a gas flow limiting device mounted on the line directly downstream of the regulator.

FIG. 02

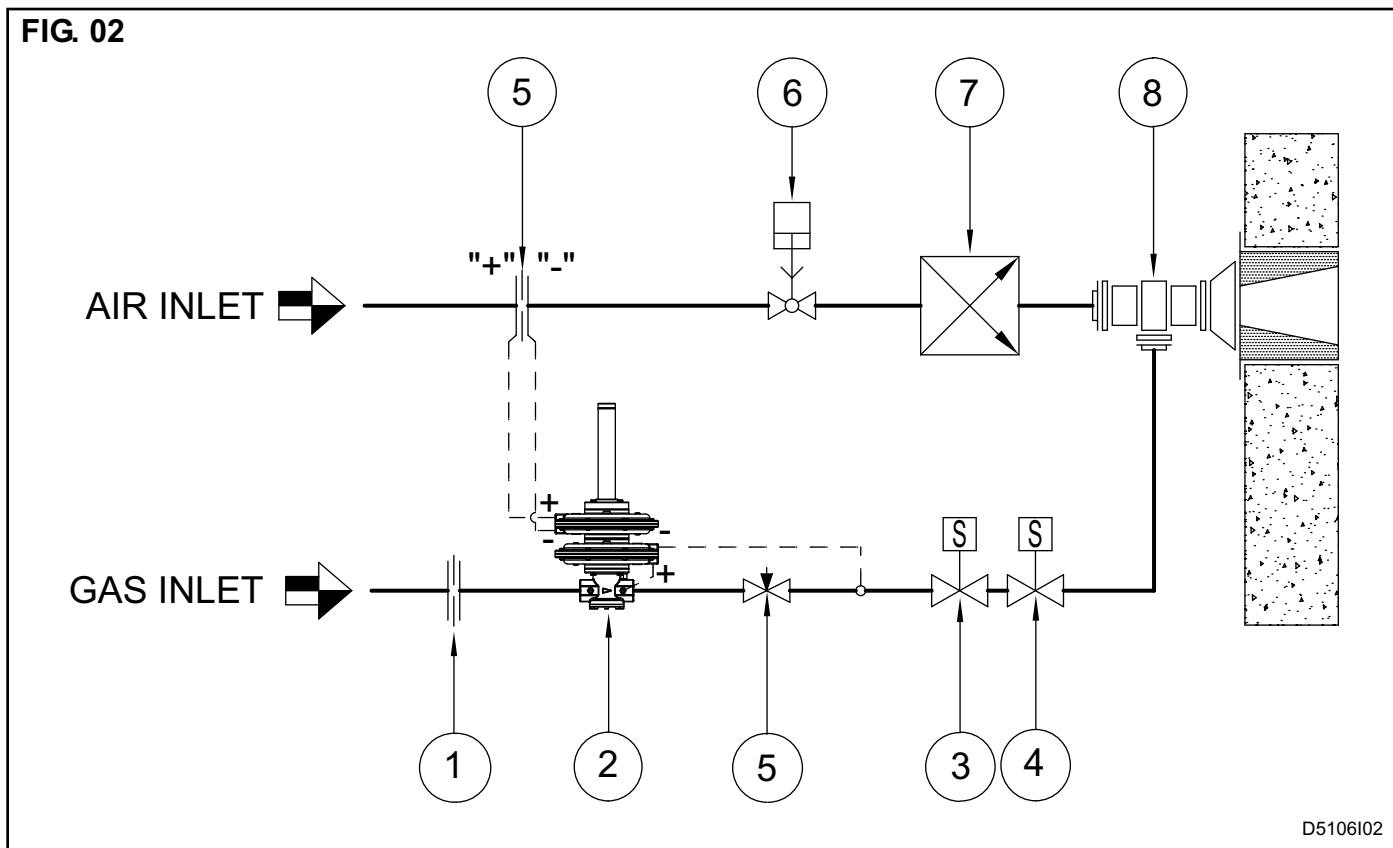

D5106I02

Position	Description
1	Δp gas measuring calibrated flange
2	Air/gas ratio regulator
3	Solenoid valve
4	Solenoid valve
5	Gas passage limiting device
6	Δp air measuring calibrated flange
7	Air flow regulation valve
8	Heat exchanger
9	Burner

APPLICATION EXAMPLES - FCR-REG-II-STD

This application is necessary when the combustion chamber is subjected to highly variable pressure (positive or negative) .

In this case, the lower chamber of the regulator is driven with the pressure of the combustion chamber as shown in the figure.

FIG. 03

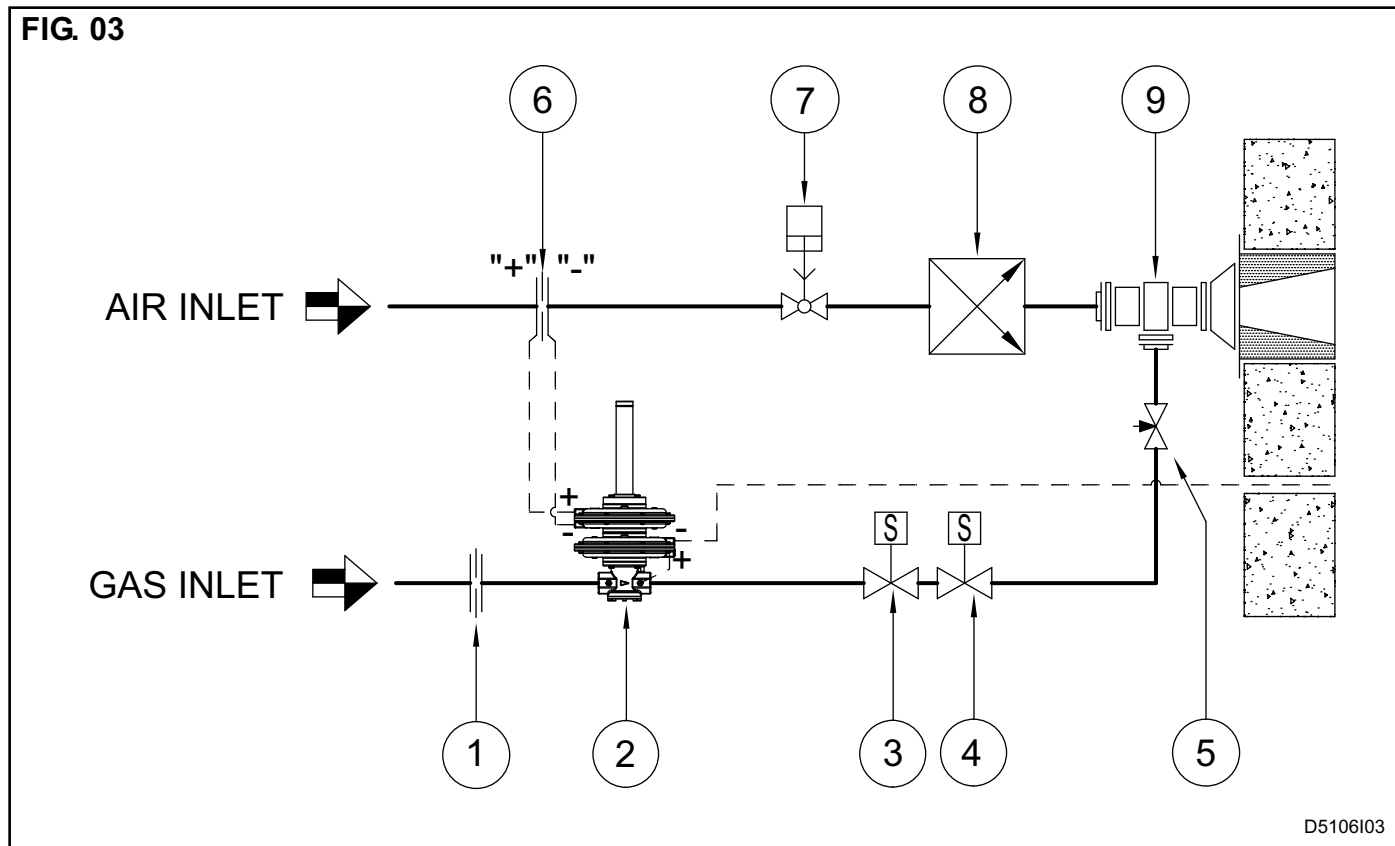

D5106I03

Position	Description
1	Δp gas measuring calibrated flange
2	Air/gas ratio regulator
3	Solenoid valve
4	Solenoid valve
5	Gas passage limiting device
6	Δp air measuring calibrated flange
7	Air flow regulation valve
8	Heat exchanger
9	Burner

APPLICATION EXAMPLES - FCR-REG-II-RMT

The FCR regulator is balanced when the differential pressure on the POP calibrated air and gas flange, are the same.

The POP calibrated orifices are sized according to the air / gas ratio you desire.

FIG. 04

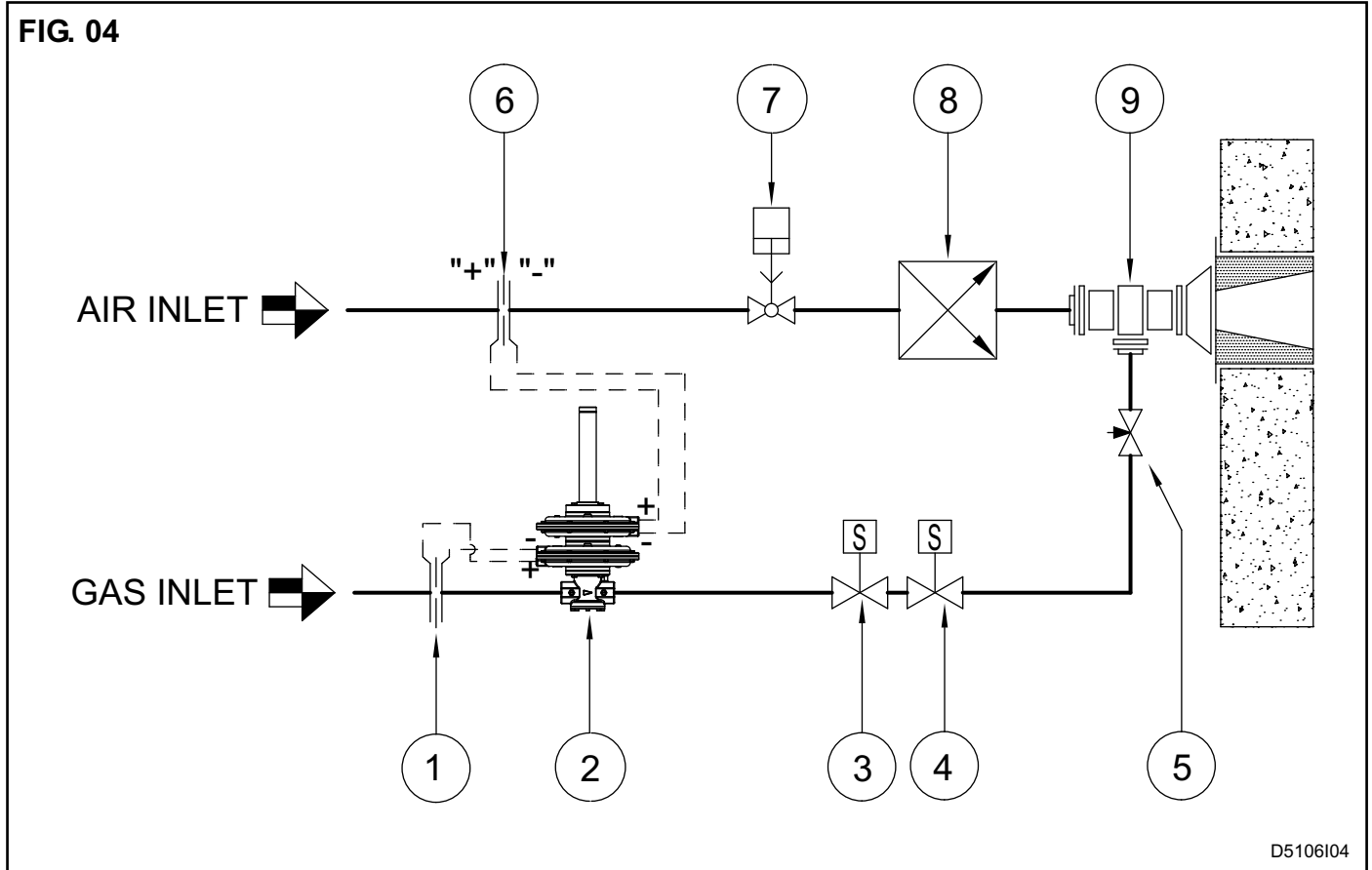

Position	Description
1	Δp gas measuring calibrated flange
2	Air/gas ratio regulator
3	Solenoid valve
4	Solenoid valve
5	Gas passage limiting device
6	Δp air measuring calibrated flange
7	Air flow regulation valve
8	Heat exchanger
9	Burner

APPLICATION EXAMPLES- FCR-REG-II-PC

The FCR-PC solution is adopted to drive a BZR-REG modulator (data sheet E5101), when the gas flow rate required by the burner is higher than that supplied by the regulator FCR-REG-II. The outlet pressure from the regulator FCR-REG-II goes to load the modulator BZR-REG.

They are however applicable in all solutions (see FIG. 1 + FIG. 4) as for the simple FCR. The ratio regulator must be mounted before the air flow control valves, fed by air flow at constant pressure.

FIG. 05

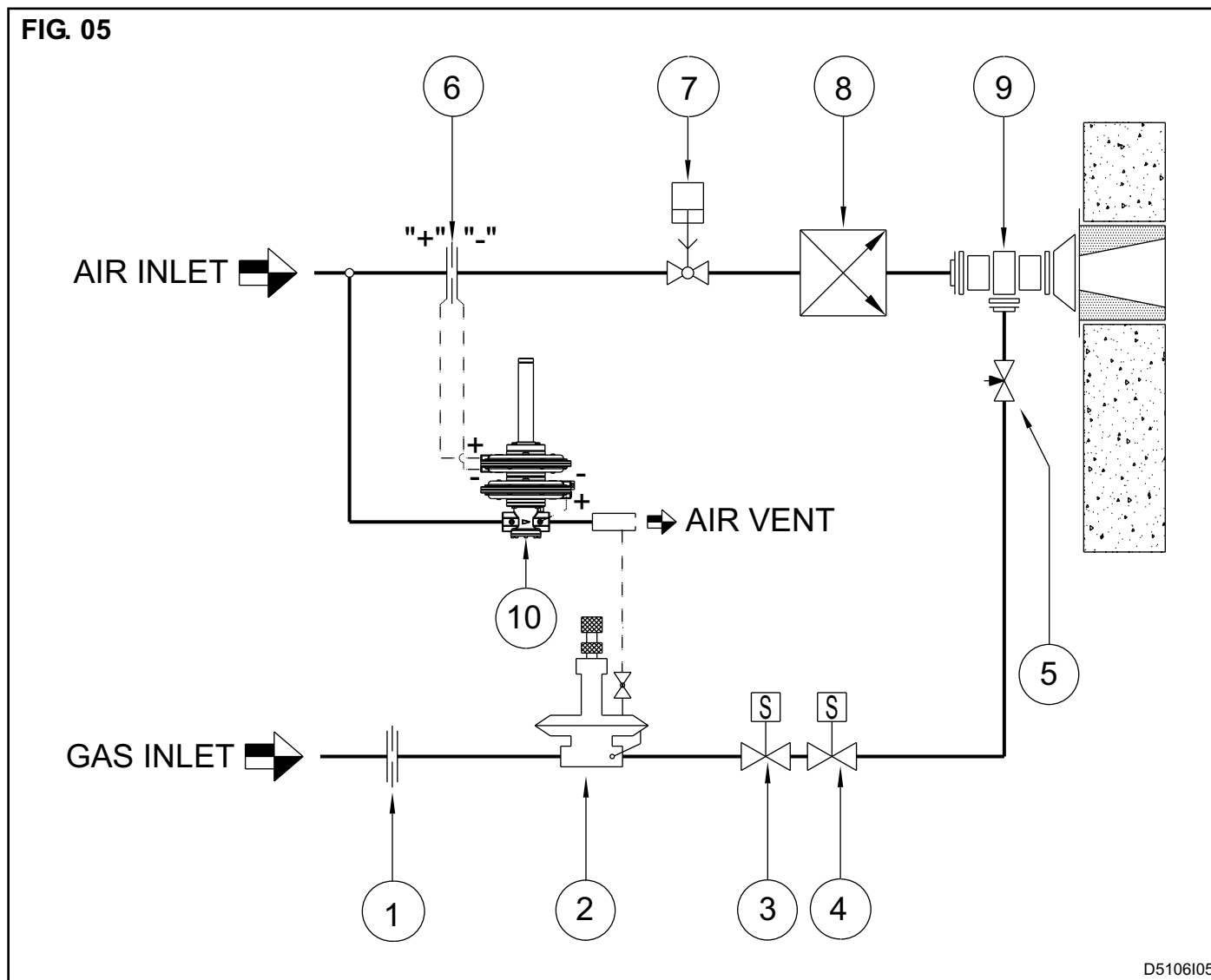

D5106I05

Posizione	Descrizione
1	Δp gas measuring calibrated flange
2	Air/gas ratio regulator
3	Solenoid valve
4	Solenoid valve
5	Gas passage limiting device
6	Δp air measuring calibrated flange
7	Air flow regulation valve
8	Heat exchanger
9	Burner
10	Remote air/gas ratio regulator

WARNINGS

- Make sure that the operating pressure and temperature of the fluid are lower than the maximum allowed. The gas pressure upstream of the regulator must be stabilized with the appropriate regulatory bodies, which provide safety devices in case of overpressure.
- The pressure regulator is not equipped with a filter. Ensure that upstream of the regulator there is a filter system with filtration of not more than 50 µm.

- Check the correct installation of the valve before starting the flow in the pipeline.
- In case of malfunction of the regulator, follow the instructions in this manual in the "MAINTENANCE" section or contact your ESA-PYRONICS service.
- Any modification or repair performed by third parties can compromise the safety of the application and automatically invalidates the guarantee conditions.

INSTALLATION

The only correct position of operation is vertical with horizontal piping on a plane surface. Mounting in any other position will cause malfunctioning.

- 1 - The arrow on the regulator body indicates the flow direction.
- 2 - Regulators should not be installed in areas where temperature exceeds the maximum operating values.
- 3 - For the piping installation, provide conical threads according to the ISO 7/1, using the appropriate thread

sealing paste. Also provide a straight section of pipe upstream and downstream of the regulator of at least 100 mm.

- 4 - Regarding the connection of the impulse signals of the regulator, use metal pipes with an inner section of at least 8 mm Ø. Make sure that these tubes are not squeezed or deformed in any way as it could affect the proper signal transmission to the instrument.

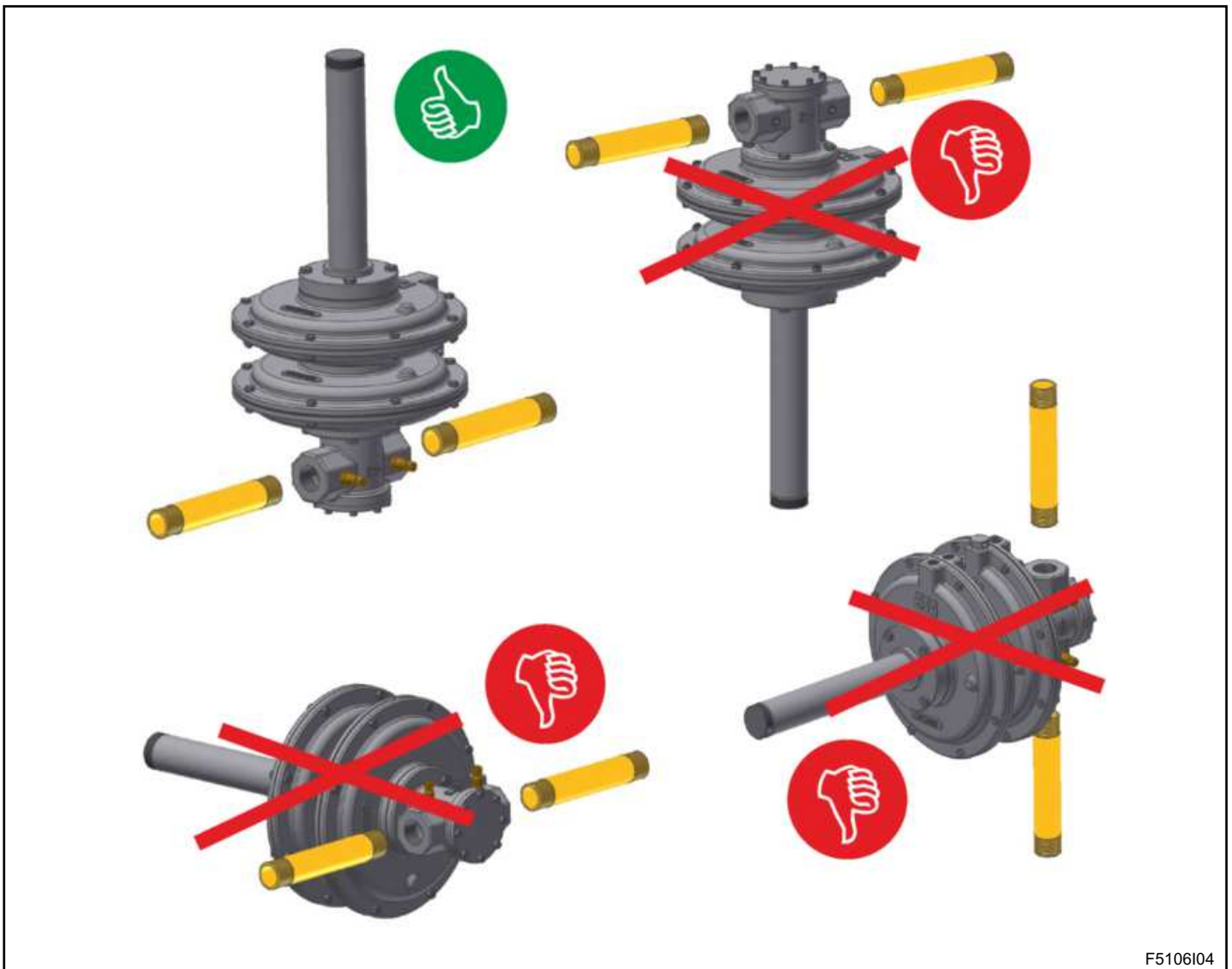

F5106I04

REGULATION AND SETTING

All FCR-REG-II combustion ratio regulators during the production phase are subjected to calibration and functional testing; as they are constructed and assembled with specific criteria and very small tolerances.

1 - Open the cap of the stem, where an adjustment screw is housed.

2 - For a correct calibration of the air / gas ratio at minimum power, turn the spring in the following way:

- a) tighten the adjustment screw to increase the output pressure of the instrument.
- b) unscrew the adjusting screw to decrease the output pressure of the instrument.

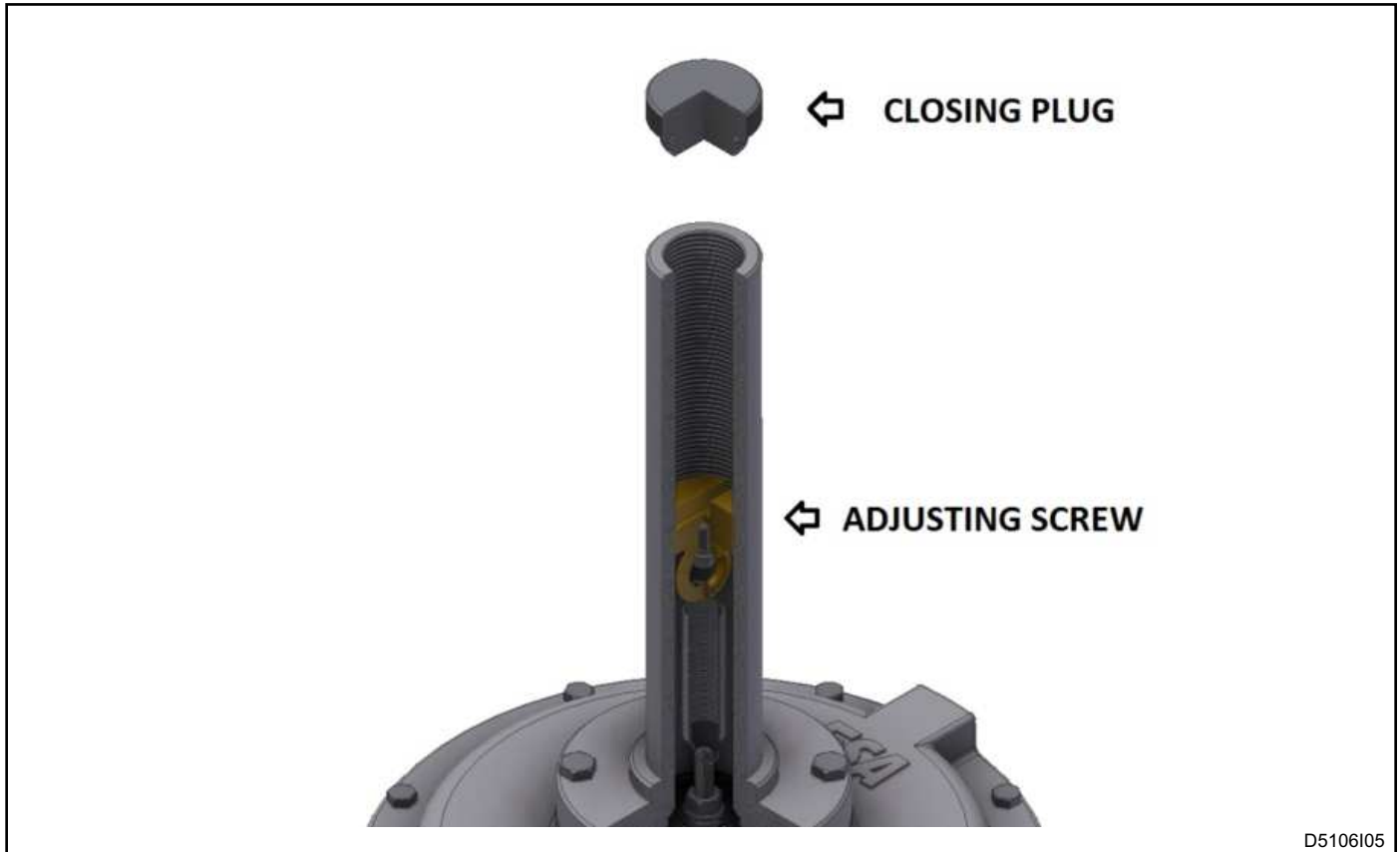

D5106105

MAINTENANCE

FCR-REG-II-STR / RMT

You cannot repair regulators or their components. The repair must be performed by qualified ESA PYRONICS personnel in compliance with applicable regulations. For each type of calibration or repair it is strongly recommended to contact ESA PYRONICS.

FCR-REG-II-PC

Apply the recommendations of the previous paragraph. In addition, a six-month check is required for the clamp on the output of the regulator (see p. 13). Make sure the vent hole is not obstructed, if it is, restore the configuration by cleaning the hole with compressed air.

OVERALL DIMENSIONS - FCR-REG-II-STD REGULATOR

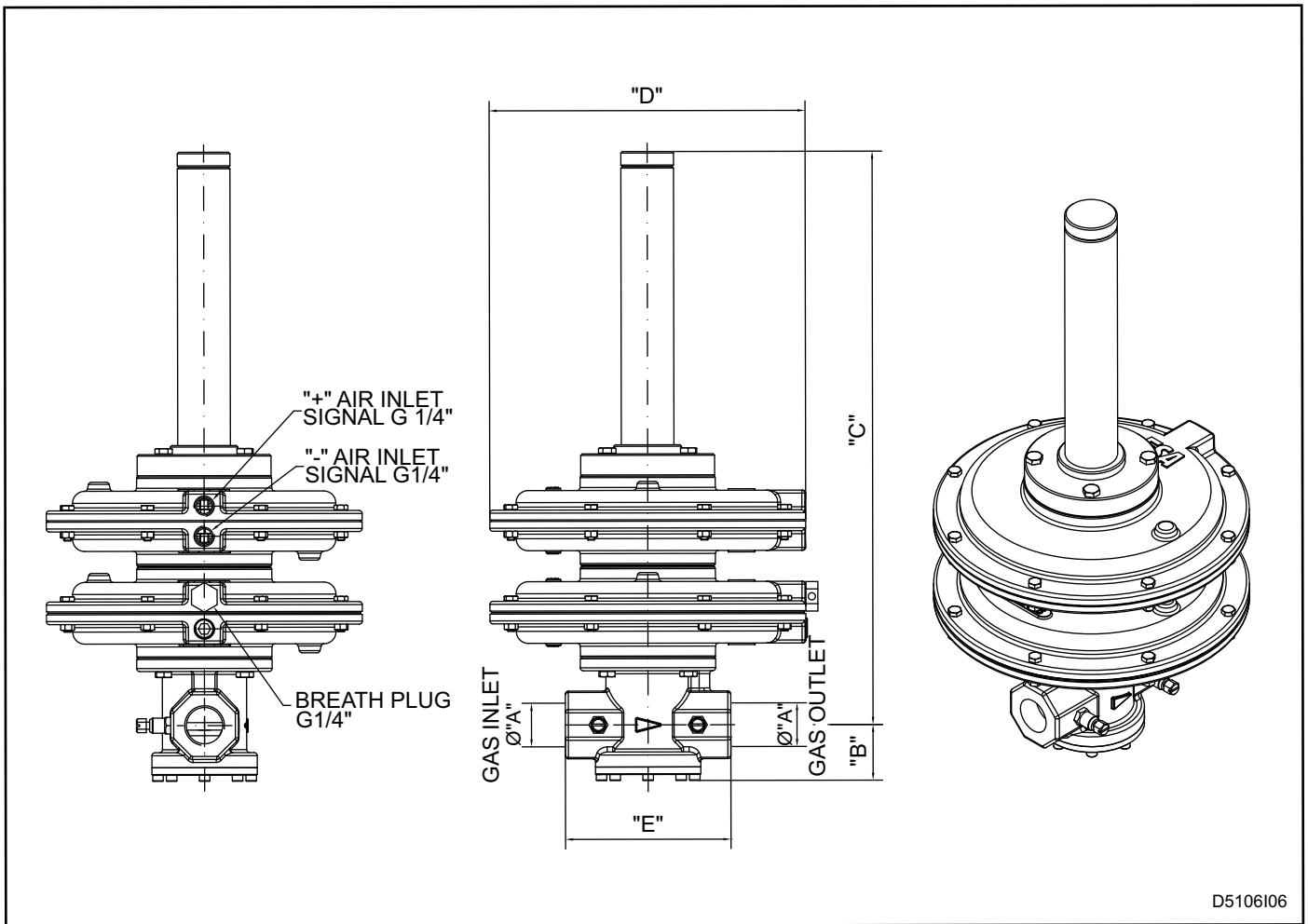

D5106106

Model	Gas Ø A	B [mm]	C [mm]	D [mm]	E [mm]	Mass [Kg]
6 FCR-REG-II-STD	G 3/4"	37	381	210	110	4,30
8 FCR-REG-II-STD	G 1"	37	381	210	110	4,25
12 FCR-REG-II-STD	G 1.1/2"	53	399	210	140	4,95

OVERALL DIMENSIONS - FCR-REG-II-RMT REGULATOR

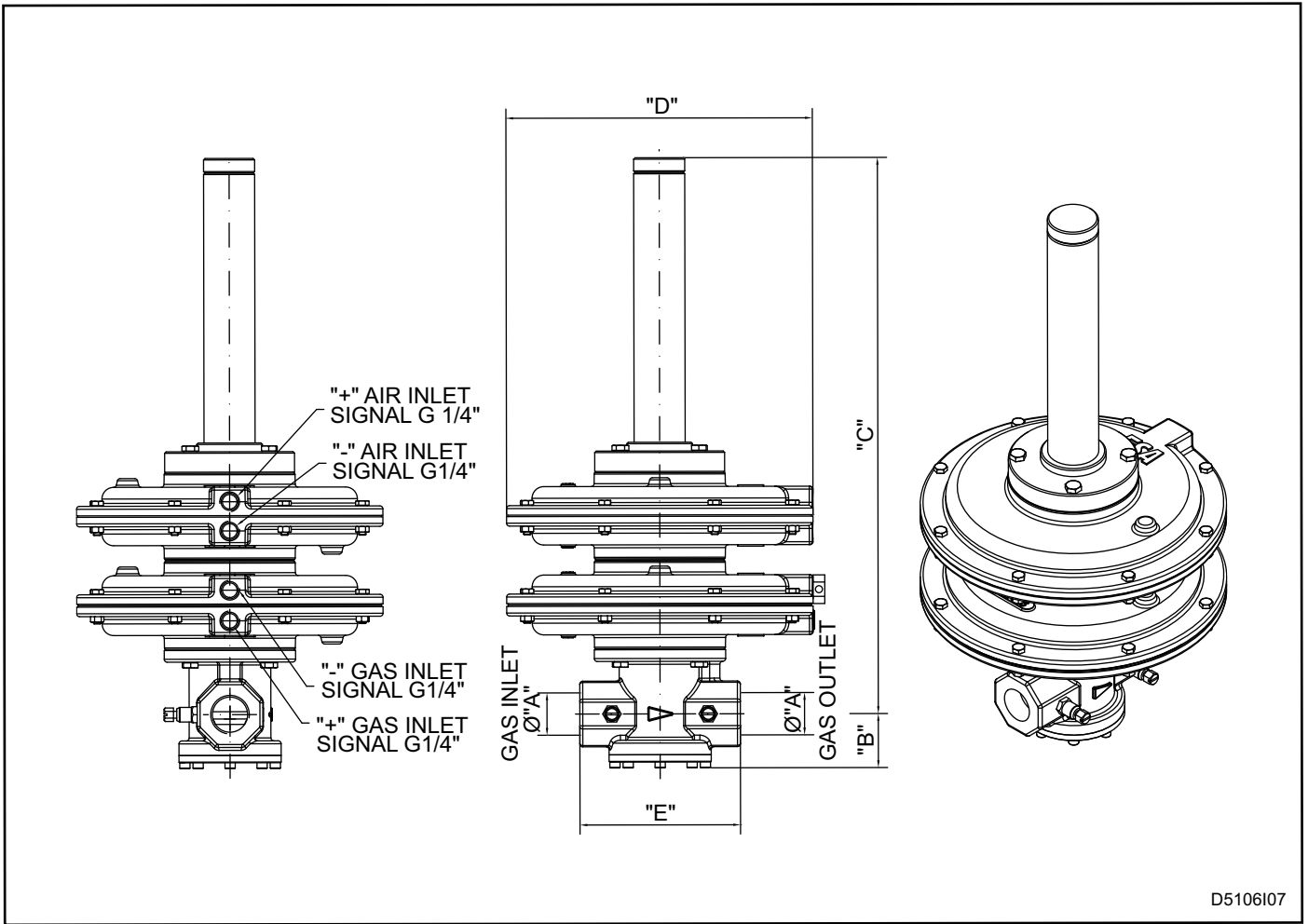

D5106107

Model	Gas Ø A	B [mm]	C [mm]	D [mm]	E [mm]	Mass [Kg]
6 FCR-REG-II-RMT	G 3/4"	37	381	210	110	4,30
8 FCR-REG-II-RMT	G 1"	37	381	210	110	4,25
12 FCR-REG-II-RMT	G 1.1/2"	53	399	210	140	4,95

OVERALL DIMENSIONS - 6-FCR-REG-II-PC REGULATOR

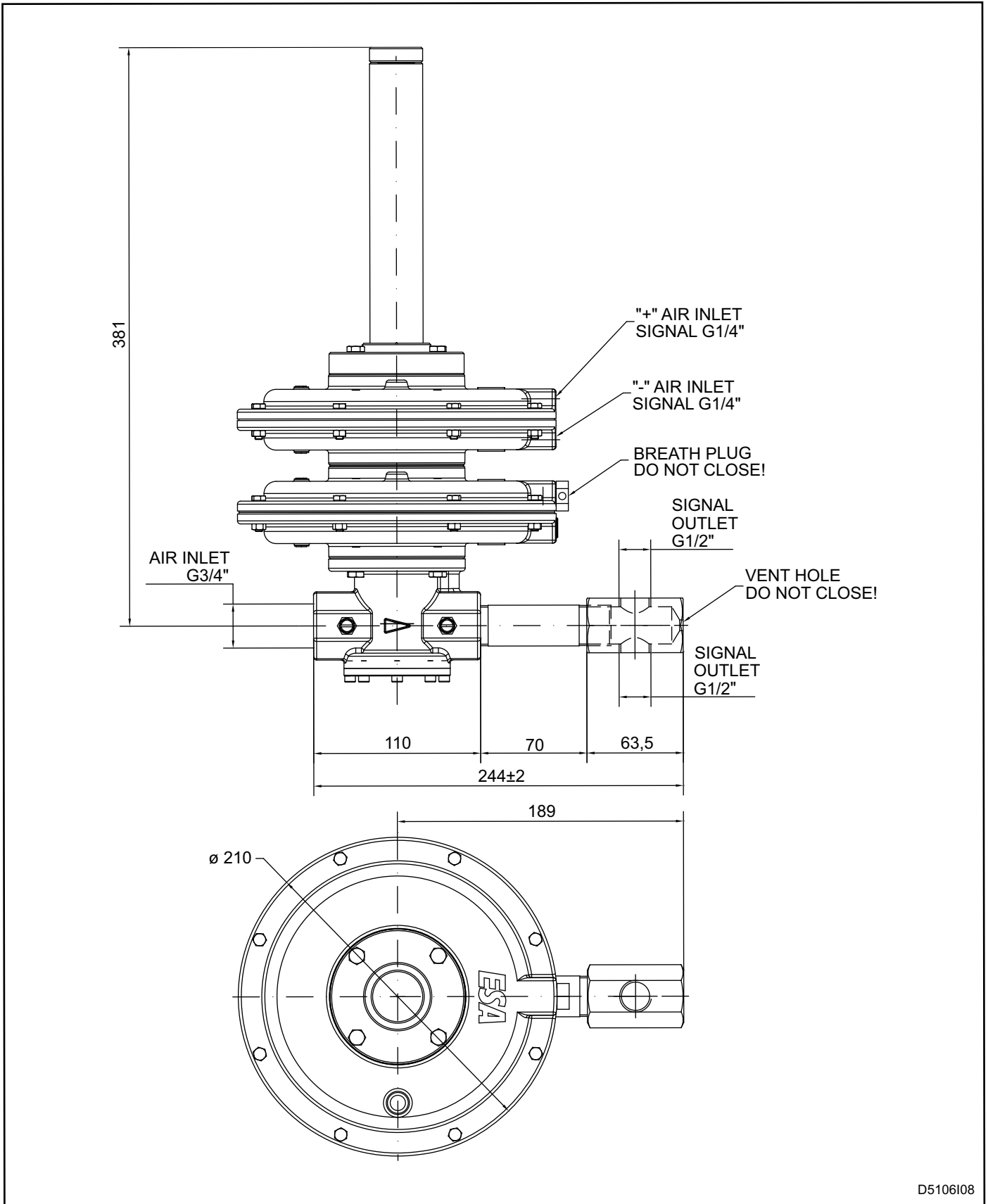

D5106I08

ORDERING CODE - REGULATOR



Model		01
6FCR	6	
8FCR	8	
12FCR	12	

Type		02
Standard	STR	
Pilot control	PC*	
Remote charge	RMT	

* only 6-FCR-REG-II-PC model