

Accessories



**Capsule pressure
gauges button cock**

SAM & ROT-G (E5714 rev. 03 -12/11/2009)

GENERAL WARNINGS:



■ All installation, maintenance, ignition and setting operations must be performed by qualified personnel and respect the laws in force at the time and place of installation.

■ To avoid damage to people and things, it is essential to observe all the points indicated in this handbook. The reported indications do not exonerate the Client/User from observing general or specific laws concerning accidents and environmental safeguarding.

■ The operator must wear proper DPI clothing (shoes, helmets...) and respect the general safety, prevention and precaution norms.

■ To avoid the risks of burns or high voltage electrocution, the operator must avoid all contact with the burner and its control devices during the ignition phase and while it is running at high temperatures.

■ All ordinary and extraordinary maintenance must be performed when the system is stopped.

■ To assure correct and safe use of the combustion plant, it is of extreme importance that the contents of this document be brought to the attention of and be meticulously observed by all personnel in charge of controlling and working the devices.

■ The functioning of a combustion plant can be dangerous and cause injuries to persons or damage to equipment. Every burner must be provided with certified combustion safety and supervision devices.

■ The burner must be installed correctly to prevent any type of accidental/undesired heat transmission from the flame to the operator or the equipment.

■ The performances indicated in this technical document regarding the range of products are a result of experimental tests carried out at ESA-PYRONICS. The tests have been performed using ignition systems, flame detectors and supervisors developed by ESA-PYRONICS. The respect of the above mentioned functioning conditions cannot be guaranteed if equipment, which is not present in the ESA-PYRONICS catalogue, is used.

DISPOSAL:



To dispose of the product, abide by the local legislations regarding it.

GENERAL NOTES:



■ In accordance to the internal policy of constant quality improvement, ESA-PYRONICS reserves the right to modify the technical characteristics of the present document at any time and without warning.

■ It is possible to download technical sheets which have been updated to the latest revision from the **www.esapyronics.com** website.

■ The products manufactured by ESA-PYRONICS have been created in conformity to the **UNI EN 746-2:2010** Norms: Equipment for industrial thermal process - Part 2: Safety requirements for combustion and the movement and treatment of combustible elements. This norm is in harmony with the Machine Directive **2006/42/CE**. It is certified that the products in question respect all the requirements prescribed by the above mentioned Norms and Directives.

■ Certified in conformity with the **UNI EN ISO 9001** Norm by DNV GL.

CERTIFICATIONS:



EN837-3 Diaphragm and capsule pressure gauges - Dimensions, metrology, requisites and tests.

90/396/EEC Button cock valves are certified with DVGW. CE Gas apparatus Directive (90/396/EEC)

The products comply with the requirements of the Eurasian market (Russia, Belarus and Kazakhstan) and are exempt from the EAC certification ref. **Doc. 01-11/437**

CONTACTS / SERVICE:



Headquarters:

Esa S.p.A.
Via Enrico Fermi 40
24035 Curno (BG) - Italy
Tel +39.035.6227411
Fax +39.035.6227499
esa@esacombustion.it

International Sales:

Pyronics International s.a.
Zoning Industriel, 4ème rue
B-6040 Jumet - Belgium
Tel +32.71.256970
Fax +32.71.256979
marketing@pyronics.be

www.esapyronics.com

SAM identifies a series of capsule pressure gauges destined for easy reading and installation. Furthermore, to guarantee the duration of the instrument, the manual ROT-G, button cock that protects the manometer from possible high pressures is also available.

APPLICATIONS

- Pressure checks on air and gas ducts.
- Blower inlet.
- On request, degreased pressure gauges for oxygen use.

CHARACTERISTICS

SAM PRESSURE GAUGE:

- Range: from -25 mbar for empty meter up to 10 bar per pressure
- Precision class: $\pm 1,6\%$
- Room temperature: $-20 +60^{\circ}\text{C}$
- Process fluid temperature: max 60°C
- Working pressure: (max for 15 min.) 75% of VFS
- Over pressure: not allowed
- Protection degree: IP 65 according to IEC 529
- Zero regulation: manual

MATERIAL COMPOSITION:

- Case: stainless steel AISI 304
- Ring: bayonet type AISI 304
- Dial: in aluminium, white background, with scales and numbers in black
- Indicating pointer: black in aluminium
- Transparent: glass
- Transparent gasket: in EPDM
- Movement: in brass high sensitivity
- Process attachment pin : brass OT 58

ACCESSORY CHARACTERISTICS

ROT-G COCK PIN:

- Tightness: "O" ring
- Spear valve seat: cylindrical
- Handwheel: button
- Maximum working pressure: 30 bar
- Working temperature: $-20^{\circ}\text{C} / +100^{\circ}\text{C}$
- Nominal pressure stage: MOP 5
- Thread: according to ISO 7-1

MATERIAL COMPOSITION:

- Body: brass OT 58

SAM



F5714103

ROT-G



F5714104

MODELS AND SCALES

Model	Scale	Sensitive element
SAM-25	0 ÷ 25 mbar	membrana
SAM-40	0 ÷ 40 mbar	membrana
SAM-60	0 ÷ 60 mbar	membrana
SAM-100	0 ÷ 100 mbar	membrana
SAM-160	0 ÷ 160 mbar	membrana
SAM-250	0 ÷ 250 mbar	membrana
SAM-500	0 ÷ 500 mbar	membrana
SAM-1000	0 ÷ 1 bar	bourdon
SAM-2500	0 ÷ 2,5 bar	bourdon
SAM-5000	0 ÷ 5 bar	bourdon
SAM-10000	0 ÷ 10 bar	bourdon

DESCRIPTION

The SAM pressure gauges have been created to facilitate pressure readings and can be installed in any direction and in any air, gas or combustion plant duct. The wide range of measuring scales available also guarantees an easier and more versatile choice of product according to

one 's needs. The ROT-G button cock protects the gauge from possible overpressure due to the fact that the button mechanism activates the gauge only if needed to be read.

WARNINGS

■ - Before installation check the integrity of the gauge paying particular attention whilst handling it, so as to avoid damaging it and consequently compromising its functioning.

■ - Periodically set the gauge, thus avoiding error signals which could compromise the correct functioning of the plant and provoking consequences on persons.

INSTALLATION

- - The pressure gauge can be installed in any position or combustion plant duct direction (04).
- - Assemble the components placing sealing paste on the threads (05), carefully screwing them on using appropriate fixing wrenches.
- - Pay attention to the direction of the arrows placed on the button cock (02) which indicate its correct assembly.

ZERO REGULATION

Operate without pressure on the duct. Unscrew the external ring of the dial and remove the glass with the gasket. With a screwdriver unscrew the middle screw, which is the indicating pointer pin. At this

point the aluminium pointer is loose. Manually bring the arrow to the Zero position on the scale, resting it on the pin near the Zero indication. Carefully rescrew the middle screw on. Now the Zero is regulated.

MAINTENANCE

It is not possible to repair neither the gauge nor its components. If the gauge breaks it is necessary to replace the damaged part, therefore the purchase of spare parts to keep in stock, is strongly suggested.

- 1 - Operate with no pressure on the duct (04).
- 2 - In case you need to replace the gauge (01) or one of its components, dismantle it with an appropriate fixing wrench.
- 3 - To check which component needs to be replaced, dismantle the parts and try them out separately: pressure gauge (01), button cock (02) and adapting nipple (03).
- 4 - Proceed in replacing the part, placing sealing paste on the thread (05) and screwing on with appropriate fixing wrenches.
- 5 - In case the gauge's glass dial (01) is dirty, clean it with a non aggressive detergent, if it is broken, replace it.

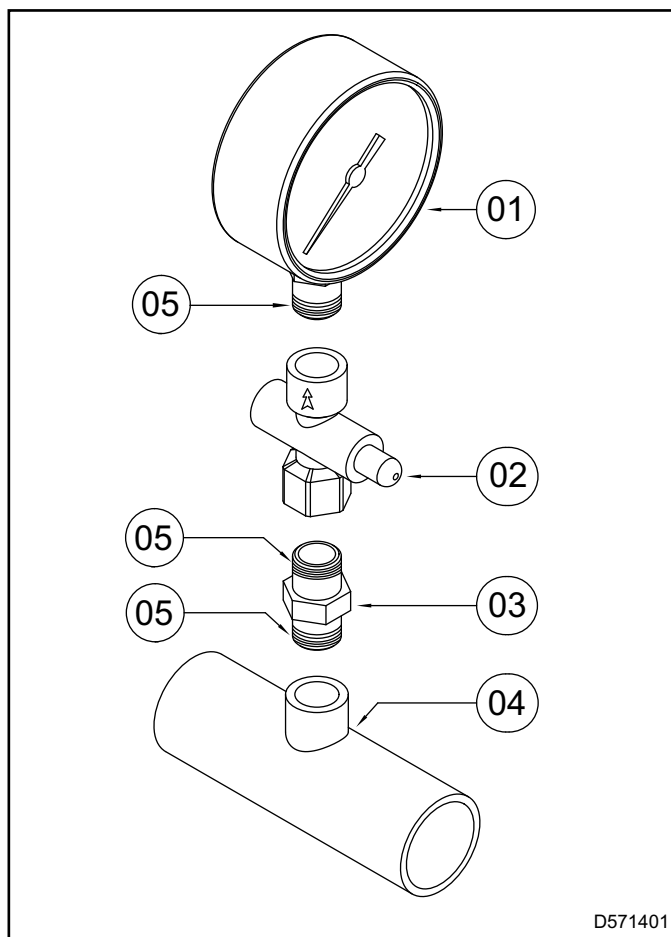

D571401

SAM PRESSURE GAUGE DIMENSIONS

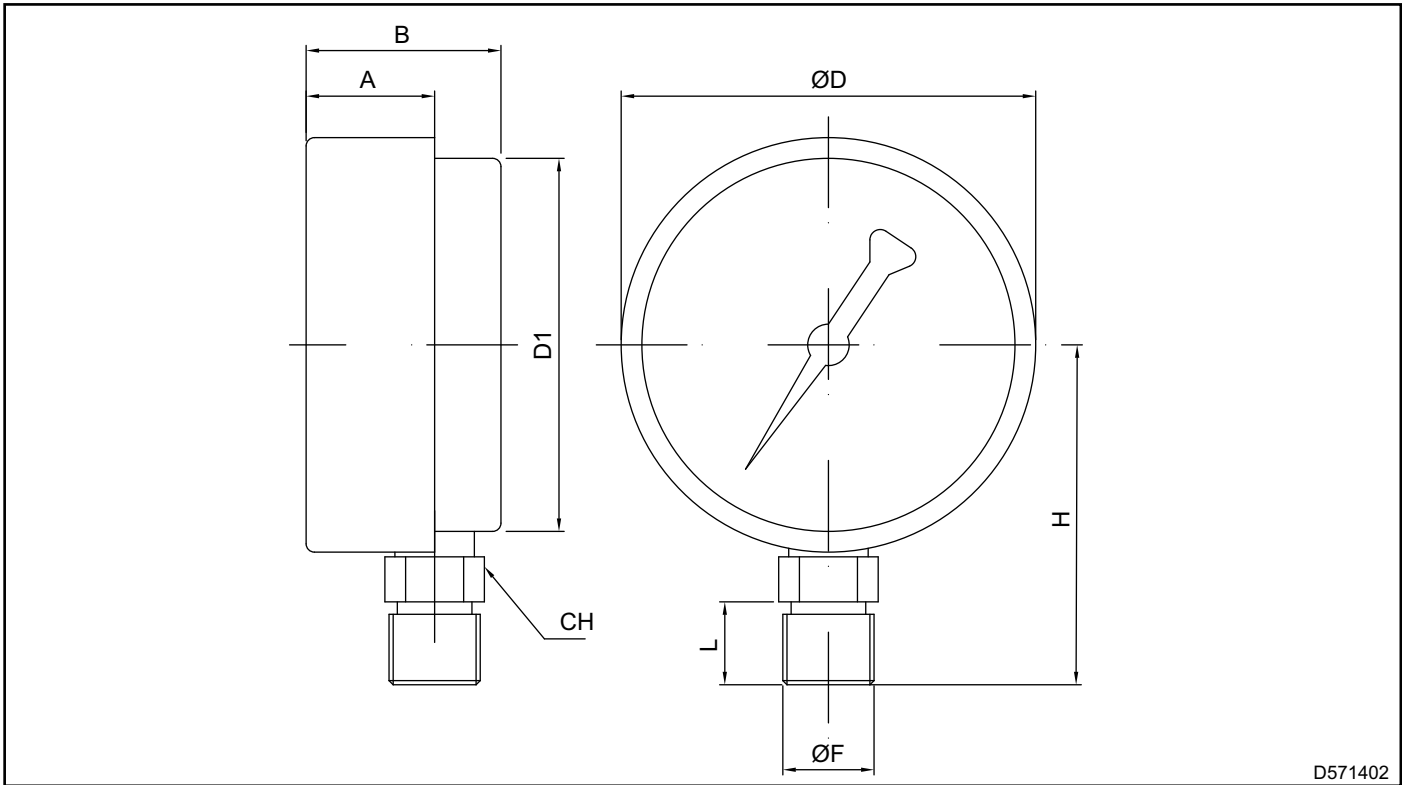

D571402

DN 100	F	L mm	A mm	B mm	D mm	D1 mm	H mm	CH mm	Weight Kg
pressure -600 ÷ +600 mbar	G - 1/2" gas	20	14	53	113	99	90	22	0,575
	G - 1/2" npt								
pressure > 600 mbar	G - 1/2" gas	20	14	41	113	99	90	22	0,575
	G - 1/2" npt								

ROT-G BUTTON COCK DIMENSIONS (ACCESSORY)

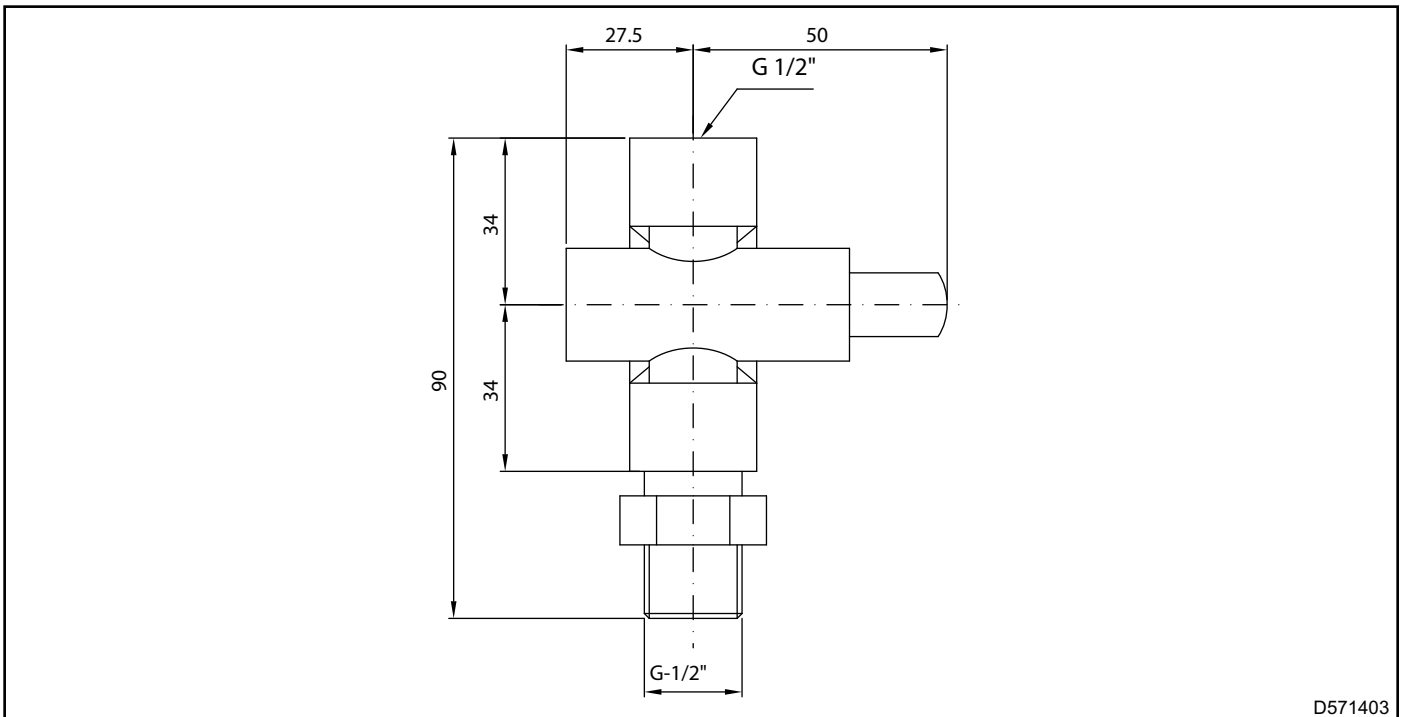

D571403

ORDERING CODES - COMPLETE PRESSURE GAUGE

SAM - -
01 02

MODEL (SCALE)		01
0 ÷ 25 mbar	25	
0 ÷ 1 bar	1000	
see table pag. 4	...	

02 ACCESSORIES*	
Button cock	ROT-G

* The accessories are not included with the guage.
To be specified during ordering phase.